

CROSS-RECESS  
SIZE #1

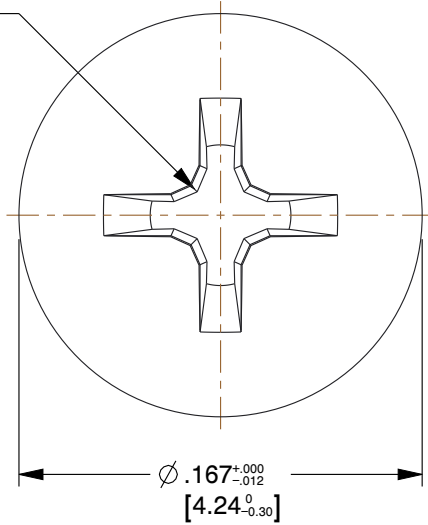

2-56 UNC-2A  
THREAD

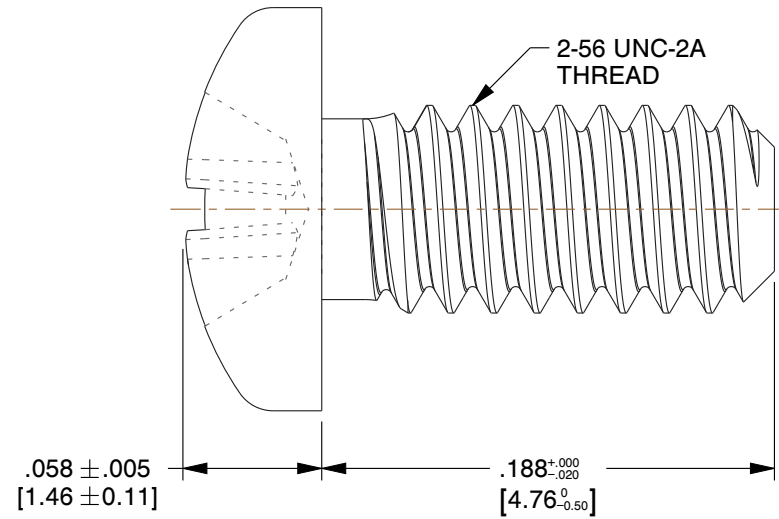

**NOTES:**

1. HEAD TYPE: Pan
2. MEETS / STANDARD: ASME B18.6.3
3. FINISH: Zinc Cr3
4. DRIVE TYPE: Phillips
5. MATERIAL: Steel
6. RoHS: Compliant

<b>COMPONENT</b>		Machine Screw	
<b>2C18PPMZR</b>		<b>UNIT</b>	IN [MM]
		<b>SHEET</b>	1 of 1
2-56 X 3/16 PH PAN STL ZN CR3 RoHS		<b>SCALE</b>	12.57



www.olander.com

This file and any associated information and specifications are provided for reference and evaluation purposes only, and is subject to change without notice. Olander makes no representations, warranties or guarantees as to the appropriateness, accuracy, completeness, or suitability for any purpose, of the file, information or specifications. You are solely responsible for the use of the file, information or specifications.

This drawing is the property of OLANDER. It contains confidential, proprietary information that is OLANDER property. Do not disclose to or duplicate for others except as authorized by OLANDER.