

## INA19x Current Shunt Monitor –16 V to +80 V Common-Mode Range

### 1 Features

- Wide Common-Mode Voltage: –16 V to +80 V
- Low Error: 3.0% Over Temp (maximum)
- Bandwidth: Up to 500 kHz
- Three Transfer Functions Available: 20 V/V, 50 V/V, and 100 V/V
- Quiescent Current: 900  $\mu$ A (maximum)
- Complete Current Sense Solution

### 2 Applications

- Welding Equipment
- Notebook Computers
- Cell Phones
- Telecom Equipment
- Automotive
- Power Management
- Battery Chargers

### 3 Description

The INA193–INA198 family of current shunt monitors with voltage output can sense drops across shunts at common-mode voltages from –16 V to +80 V, independent of the INA19x supply voltage. They are available with three output voltage scales: 20 V/V, 50 V/V, and 100 V/V. The 500 kHz bandwidth simplifies use in current control loops. The INA193–INA195 devices provide identical functions but alternative pin configurations to the INA196–INA198 devices, respectively.

The INA193–INA198 devices operate from a single 2.7-V to 18-V supply, drawing a maximum of 900  $\mu$ A of supply current. They are specified over the extended operating temperature range (–40°C to +125°C), and are offered in a space-saving SOT-23 package.

#### Device Information<sup>(1)</sup>

PART NUMBER	PACKAGE	BODY SIZE (NOM)
INA193	SOT-23 (5)	2.90 mm x 1.60 mm
INA194		
INA195		
INA196		
INA197		
INA198		

(1) For all available packages, see the orderable addendum at the end of the datasheet.

#### Simplified Schematic

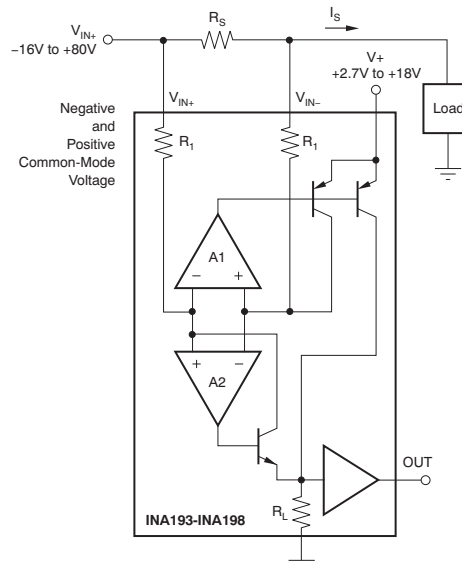

## Table of Contents

<b>1 Features</b> .....	<b>1</b>	8.3 Feature Description.....	<b>12</b>
<b>2 Applications</b> .....	<b>1</b>	8.4 Device Functional Modes.....	<b>16</b>
<b>3 Description</b> .....	<b>1</b>	<b>9 Application and Implementation</b> .....	<b>22</b>
<b>4 Revision History</b> .....	<b>2</b>	9.1 Application Information.....	<b>22</b>
<b>5 Device Comparison Table</b> .....	<b>3</b>	9.2 Typical Application .....	<b>22</b>
<b>6 Pin Configuration and Functions</b> .....	<b>3</b>	<b>10 Power Supply Recommendations</b> .....	<b>23</b>
<b>7 Specifications</b> .....	<b>4</b>	<b>11 Layout</b> .....	<b>23</b>
7.1 Absolute Maximum Ratings .....	<b>4</b>	11.1 Layout Guidelines .....	<b>23</b>
7.2 ESD Ratings .....	<b>4</b>	11.2 Layout Example .....	<b>24</b>
7.3 Recommended Operating Conditions.....	<b>4</b>	<b>12 Device and Documentation Support</b> .....	<b>25</b>
7.4 Thermal Information .....	<b>4</b>	12.1 Related Links .....	<b>25</b>
7.5 Electrical Characteristics.....	<b>5</b>	12.2 Trademarks .....	<b>25</b>
7.6 Typical Characteristics.....	<b>7</b>	12.3 Electrostatic Discharge Caution.....	<b>25</b>
<b>8 Detailed Description</b> .....	<b>11</b>	12.4 Glossary .....	<b>25</b>
8.1 Overview .....	<b>11</b>	<b>13 Mechanical, Packaging, and Orderable</b>	
8.2 Functional Block Diagram .....	<b>11</b>	<b>Information</b> .....	<b>25</b>

## 4 Revision History

NOTE: Page numbers for previous revisions may differ from page numbers in the current version.

Changes from Revision F (February 2010) to Revision G	Page
<ul style="list-style-type: none"> <li>Added <i>ESD Ratings</i> table, <i>Feature Description</i> section, <i>Device Functional Modes</i>, <i>Application and Implementation</i> section, <i>Power Supply Recommendations</i> section, <i>Layout</i> section, <i>Device and Documentation Support</i> section, and <i>Mechanical, Packaging, and Orderable Information</i> section .....</li> </ul>	<b>4</b>

Changes from Revision E (August 2006) to Revision F	Page
<ul style="list-style-type: none"> <li>Updated document format to current standards.....</li> </ul>	<b>1</b>
<ul style="list-style-type: none"> <li>Added test conditions to Output, <i>Total Output Error</i> parameter in Electrical Characteristics: <math>V_S = +12V</math>.....</li> </ul>	<b>5</b>

## 5 Device Comparison Table

PART NUMBER	GAIN	PINOUT <sup>(1)</sup>
INA193	20 V/V	Pinout #1
INA194	50 V/V	Pinout #1
INA195	100 V/V	Pinout #1
INA196	20 V/V	Pinout #2
INA197	50 V/V	Pinout #2
INA198	100 V/V	Pinout #2

(1) See [Pin Configuration and Functions](#) for Pinout #1 and Pinout #2.

## 6 Pin Configuration and Functions

**DBV Package  
5-Pin SOT-23  
INA193, INA194, INA195 Top View**

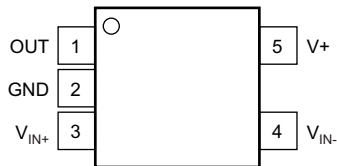

**DBV Package  
5-Pin SOT-23  
INA196, INA197, INA198 Top View**

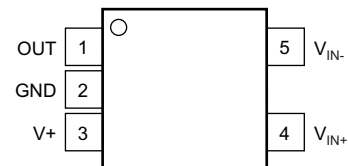

### Pin Functions

NAME	PIN		TYPE	DESCRIPTION
	INA193, INA194, INA195	INA196, INA197, INA198		
	DBV	DBV		
GND	2	2	GND	Ground
OUT	1	1	O	Output voltage
$V+$	5	3	Analog	Power supply, 2.7 V to 18 V
$V_{IN+}$	3	4	I	Connect to supply side of shunt resistor
$V_{IN-}$	4	5	I	Connect to load side of shunt resistor

## 7 Specifications

### 7.1 Absolute Maximum Ratings

over operating free-air temperature range (unless otherwise noted) <sup>(1)</sup>

	MIN	MAX	UNIT
Supply Voltage		18	V
Analog Inputs, $V_{IN+}$ , $V_{IN-}$	-18	18	V
Differential ( $V_{IN+}$ ) – ( $V_{IN-}$ )	-18	18	V
Common-Mode <sup>(2)</sup>	-16	80	V
Analog Output, $Out^{(2)}$	GND – 0.3	(V+) + 0.3	V
Input Current Into Any Pin <sup>(2)</sup>		5	mA
Operating Temperature	-55	150	°C
Junction Temperature		150	°C
Storage temperature, $T_{stg}$	-65	150	°C

- (1) Stresses beyond those listed under *Absolute Maximum Ratings* may cause permanent damage to the device. These are stress ratings only, which do not imply functional operation of the device at these or any other conditions beyond those indicated under *Recommended Operating Conditions*. Exposure to absolute-maximum-rated conditions for extended periods may affect device reliability.
- (2) Input voltage at any pin may exceed the voltage shown if the current at that pin is limited to 5mA.

### 7.2 ESD Ratings

		VALUE	UNIT
$V_{(ESD)}$ Electrostatic discharge	Human body model (HBM), per ANSI/ESDA/JEDEC JS-001, all pins <sup>(1)</sup>	±4000	V
	Charged device model (CDM), per JEDEC specification JESD22-C101, all pins <sup>(2)</sup>	±1000	

- (1) JEDEC document JEP155 states that 500-V HBM allows safe manufacturing with a standard ESD control process.
- (2) JEDEC document JEP157 states that 250-V CDM allows safe manufacturing with a standard ESD control process.

### 7.3 Recommended Operating Conditions

over operating free-air temperature range (unless otherwise noted)

		MIN	NOM	MAX	UNIT
$V_{CM}$	Common-mode input voltage		12		V
$V+$	Operating supply voltage		12		V
$T_A$	Operating free-air temperature	-40		125	°C

### 7.4 Thermal Information

THERMAL METRIC <sup>(1)</sup>		INA19x	UNIT
		DBV (SOT-23)	
		5 PINS	
$R_{\theta JA}$	Junction-to-ambient thermal resistance	221.7	°C/W
$R_{\theta JC(top)}$	Junction-to-case (top) thermal resistance	144.7	
$R_{\theta JB}$	Junction-to-board thermal resistance	49.7	
$\Psi_{JT}$	Junction-to-top characterization parameter	26.1	
$\Psi_{JB}$	Junction-to-board characterization parameter	49.0	

- (1) For more information about traditional and new thermal metrics, see the *IC Package Thermal Metrics* application report, [SPRA953](#).

## 7.5 Electrical Characteristics

All specifications at  $T_A = 25^\circ\text{C}$ ,  $V_S = 12\text{ V}$ ,  $V_{IN+} = 12\text{ V}$ , and  $V_{SENSE} = 100\text{ mV}$ , unless otherwise noted.

PARAMETER		TEST CONDITIONS	$T_A = 25^\circ\text{C}$			$T_A = -40^\circ\text{C to } +125^\circ\text{C}$			UNIT	
			MIN	TYP	MAX	MIN	TYP	MAX		
<b>INPUT</b>										
$V_{SENSE}$	Full-Scale Input Voltage	$V_{SENSE} = V_{IN+} - V_{IN-}$	0.15 $(V_S - 0.2)/\text{Gain}$			-16			V	
$V_{CM}$	Common-Mode Input Range		80			-16			V	
CMR	Common-Mode Rejection	$V_{IN+} = -16\text{ V to } 80\text{ V}$	80	94				dB		
	Common-Mode Rejection, Over Temperature	$V_{IN+} = 12\text{ V to } 80\text{ V}$				100	120	dB		
$V_{OS}$	Offset Voltage, RTI		$\pm 0.5$		2		mV			
	Offset Voltage, RTI Over Temperature					0.5	3	mV		
$dV_{OS}/dT$	Offset Voltage, RTI vs Temperature					2.5		$\mu\text{V}/^\circ\text{C}$		
PSR	Offset Voltage, RTI vs Power Supply	$V_S = 2.7\text{ V to } 18\text{ V}$ , $V_{IN+} = 18\text{ V}$				5	100	$\mu\text{V}/\text{V}$		
$I_B$	Input Bias Current, $V_{IN-}$ pin					$\pm 8$	$\pm 16$	$\mu\text{A}$		
<b>OUTPUT (<math>V_{SENSE} \geq 20\text{ mV}</math>)</b>										
G	Gain	INA193, INA196	20						V/V	
		INA194, INA197	50						V/V	
		INA195, INA198	100						V/V	
	Gain Error	$V_{SENSE} = 20\text{ mV to } 100\text{ mV}$ , $T_A = 25^\circ\text{C}$	$\pm 0.2\%$		$\pm 1\%$					
	Gain Error Over Temperature	$V_{SENSE} = 20\text{ mV to } 100\text{ mV}$				$\pm 2$				
	Total Output Error <sup>(1)</sup>	$V_{SENSE} = 100\text{ mV}$	$\pm 0.75\%$		$\pm 2.2\%$					
	Total Output Error Over Temperature					$\pm 1\%$		$\pm 3\%$		
	Nonlinearity Error	$V_{SENSE} = 20\text{ mV to } 100\text{ mV}$	$\pm 0.002\%$		$\pm 0.1\%$					
$R_O$	Output Impedance		1.5						$\Omega$	
	Maximum Capacitive Load	No Sustained Oscillation	10						nF	
Output <sup>(2)</sup>	All Devices	$-16\text{ V} \leq V_{CM} < 0\text{ V}$ , $V_{SENSE} < 20\text{ mV}$	300						mV	
		$V_S < V_{CM} \leq 80\text{ V}$ , $V_{SENSE} < 20\text{ mV}$	300							
	INA193, INA196	$0\text{ V} \leq V_{CM} \leq V_S$ , $V_S = 5\text{ V}$ , $V_{SENSE} < 20\text{ mV}$	0.4						V	
	INA194, INA197		1						V	
INA195, INA198	2						V			
<b>VOLTAGE OUTPUT<sup>(3)</sup> (<math>R_L = 100\text{ k}\Omega</math> to GND)</b>										
	Swing to $V+$ Power-Supply Rail					$(V+) - 0.1$	$(V+) - 0.2$	V		
	Swing to GND <sup>(4)</sup>					$(V_{GND}) + 3$	$(V_{GND}) + 50$	mV		
<b>FREQUENCY RESPONSE</b>										
BW	Bandwidth	INA193, INA196	$C_{LOAD} = 5\text{ pF}$	500						kHz
		INA194, INA197		300						kHz
		INA195, INA198		200						kHz

(1) Total output error includes effects of gain error and  $V_{OS}$ .

(2) For details on this region of operation, see the [Accuracy Variations as a Result of  \$V\_{SENSE}\$  and Common-Mode Voltage](#) section.

(3) See Typical Characteristic curve [Output Swing vs Output Current](#), [Figure 7](#).

(4) Specified by design.

## Electrical Characteristics (continued)

All specifications at  $T_A = 25^\circ\text{C}$ ,  $V_S = 12\text{ V}$ ,  $V_{IN+} = 12\text{ V}$ , and  $V_{SENSE} = 100\text{ mV}$ , unless otherwise noted.

PARAMETER	TEST CONDITIONS	$T_A = 25^\circ\text{C}$			$T_A = -40^\circ\text{C to } +125^\circ\text{C}$			UNIT
		MIN	TYP	MAX	MIN	TYP	MAX	
Phase Margin	$C_{LOAD} < 10\text{ nF}$		40					
SR	Slew Rate		1					$\text{V}/\mu\text{s}$
$t_S$	Settling Time (1%)		2					$\mu\text{s}$
<b>NOISE, RTI</b>								
	Voltage Noise Density		40					$\text{nV}/\sqrt{\text{Hz}}$
<b>POWER SUPPLY</b>								
$V_S$	Operating Range				2.7		18	V
$I_Q$	Quiescent Current	$V_{OUT} = 2\text{ V}$	700	900				$\mu\text{A}$
	Quiescent Current Over Temperature	$V_{SENSE} = 0\text{ mV}$			370	950		$\mu\text{A}$
<b>TEMPERATURE RANGE</b>								
	Specified Temperature Range		-40	125				$^\circ\text{C}$
	Operating Temperature Range		-55	150				$^\circ\text{C}$
	Storage Temperature Range		-65	150				$^\circ\text{C}$
$\theta_{JA}$	Thermal Resistance, SOT23		200					$^\circ\text{C}/\text{W}$

## 7.6 Typical Characteristics

All specifications at  $T_A = 25^\circ\text{C}$ ,  $V_S = 12\text{ V}$ , and  $V_{IN+} = 12\text{ V}$ , and  $V_{SENSE} = 100\text{ mV}$ , unless otherwise noted.

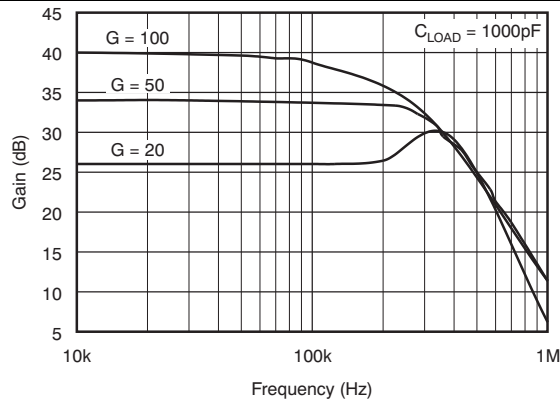

Figure 1. Gain vs Frequency

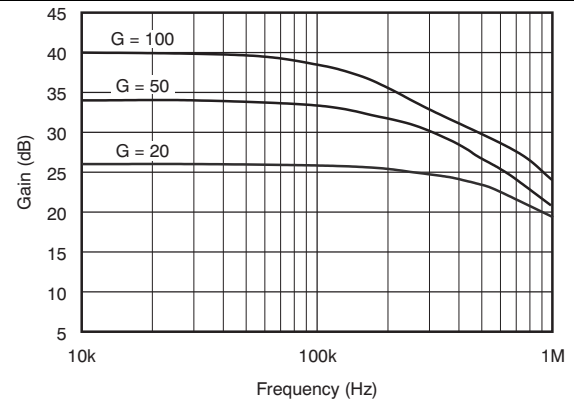

Figure 2. Gain vs Frequency

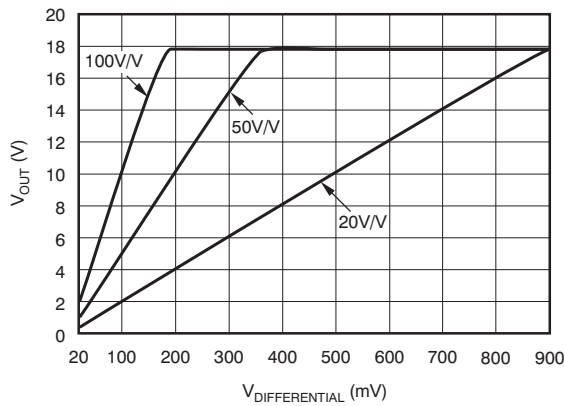

Figure 3. Gain Plot

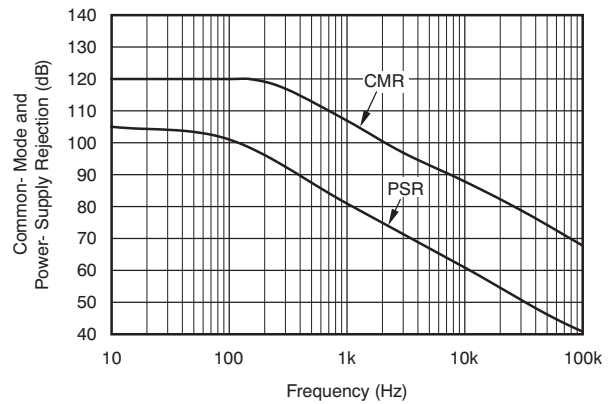

Figure 4. Common-Mode and Power-Supply Rejection vs Frequency

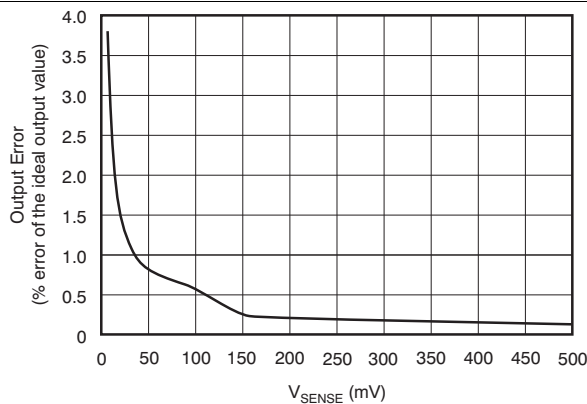

Figure 5. Output Error vs  $V_{SENSE}$

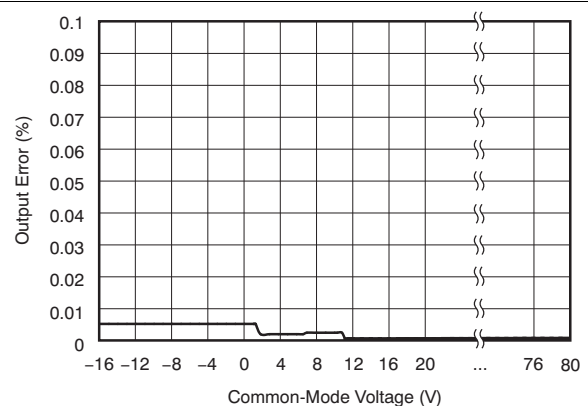
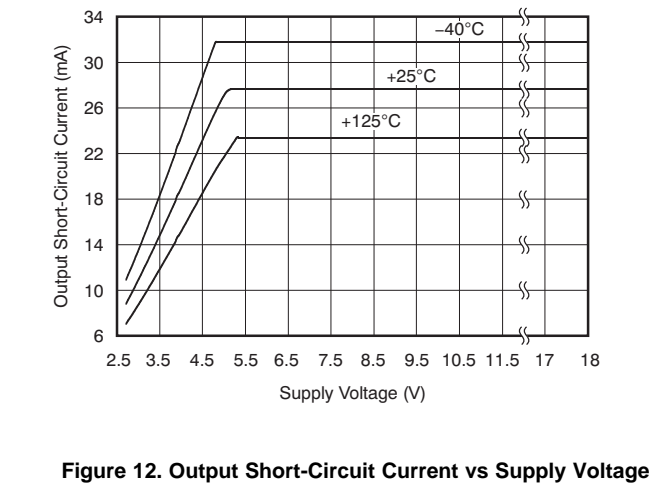
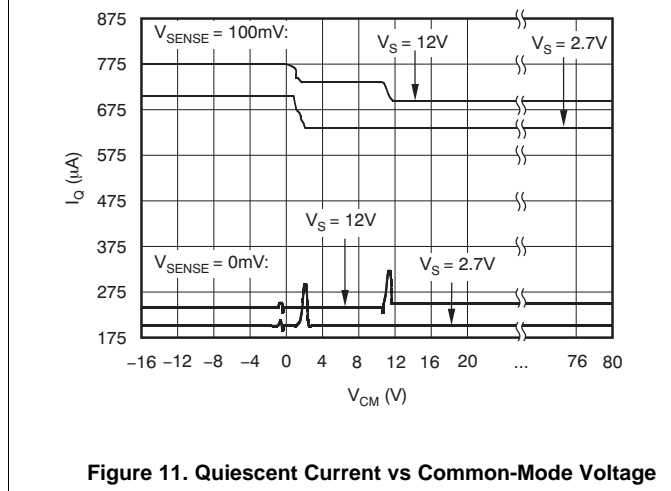
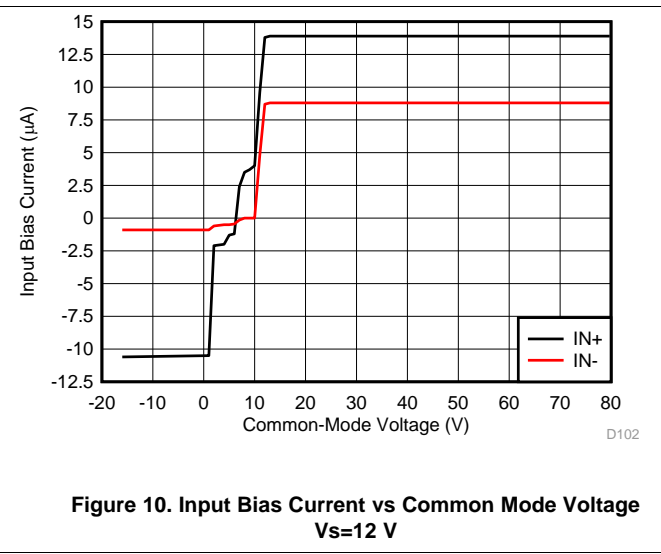
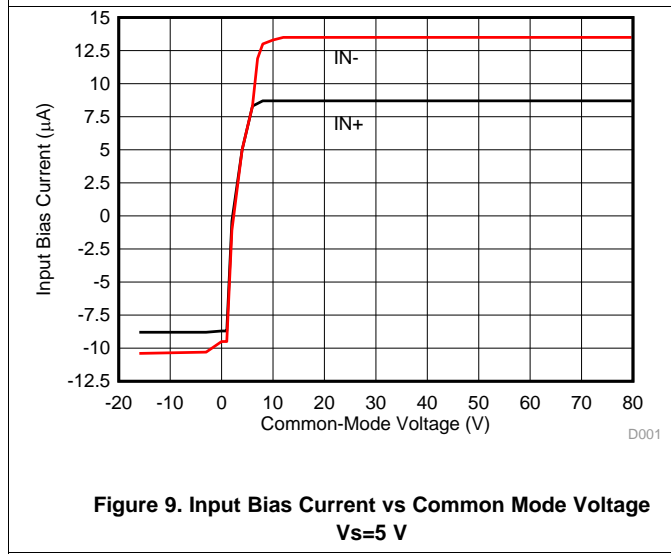
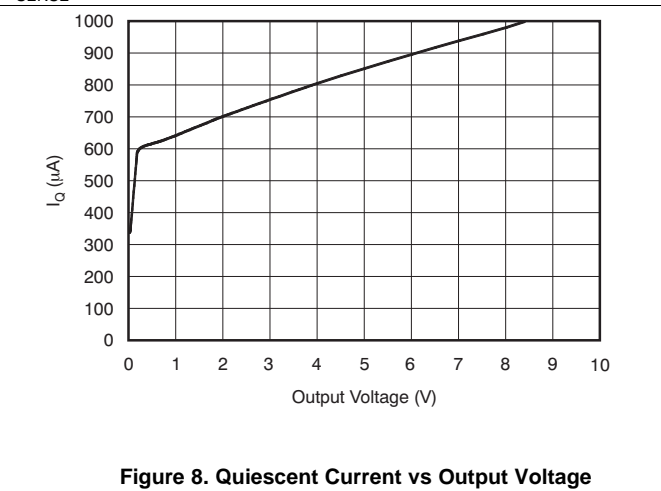
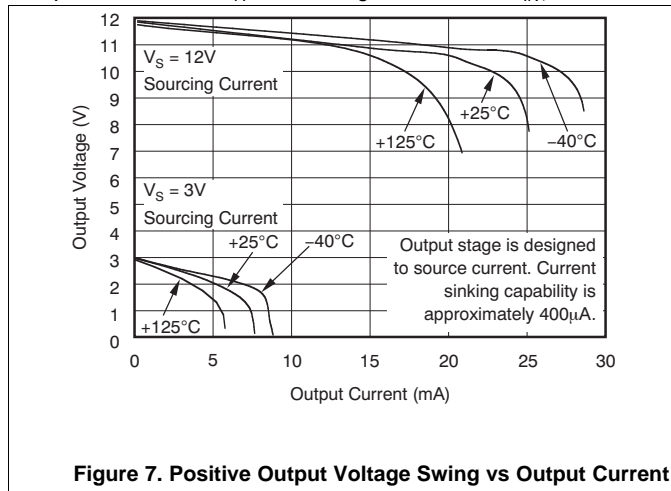

Figure 6. Output Error vs Common-Mode Voltage

### Typical Characteristics (continued)

All specifications at  $T_A = 25^\circ\text{C}$ ,  $V_S = 12\text{ V}$ , and  $V_{IN+} = 12\text{ V}$ , and  $V_{SENSE} = 100\text{ mV}$ , unless otherwise noted.





**Typical Characteristics (continued)**

All specifications at  $T_A = 25^\circ\text{C}$ ,  $V_S = 12\text{ V}$ , and  $V_{IN+} = 12\text{ V}$ , and  $V_{SENSE} = 100\text{ mV}$ , unless otherwise noted.

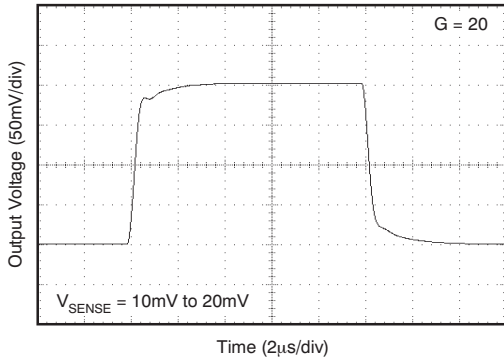

**Figure 13. Step Response**

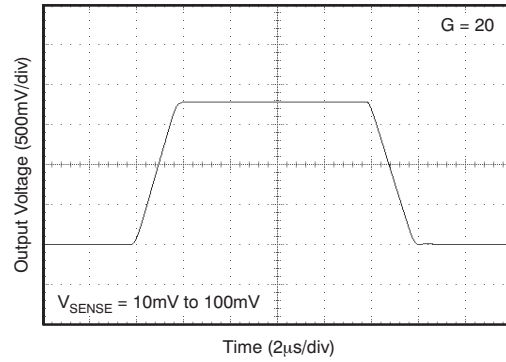

**Figure 14. Step Response**

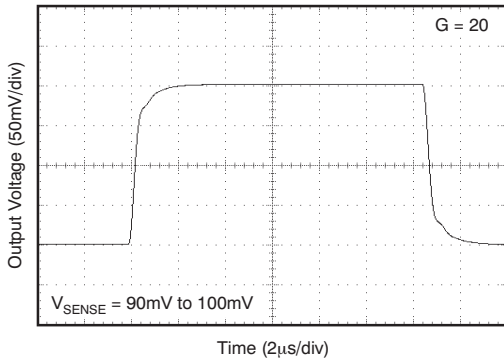

**Figure 15. Step Response**

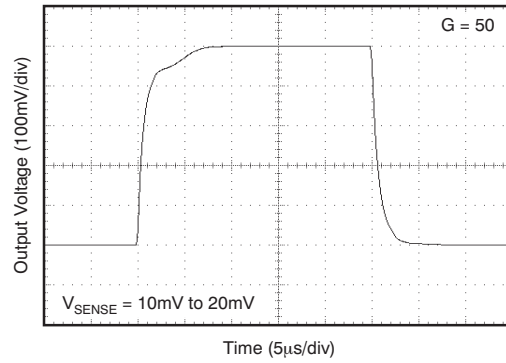

**Figure 16. Step Response**

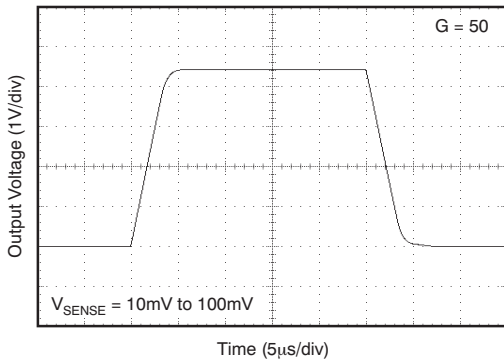

**Figure 17. Step Response**

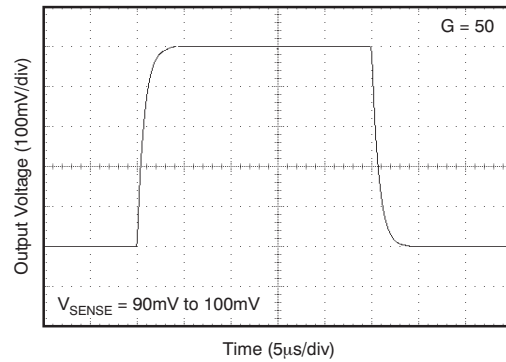

**Figure 18. Step Response**

## Typical Characteristics (continued)

All specifications at  $T_A = 25^\circ\text{C}$ ,  $V_S = 12\text{ V}$ , and  $V_{IN+} = 12\text{ V}$ , and  $V_{SENSE} = 100\text{ mV}$ , unless otherwise noted.

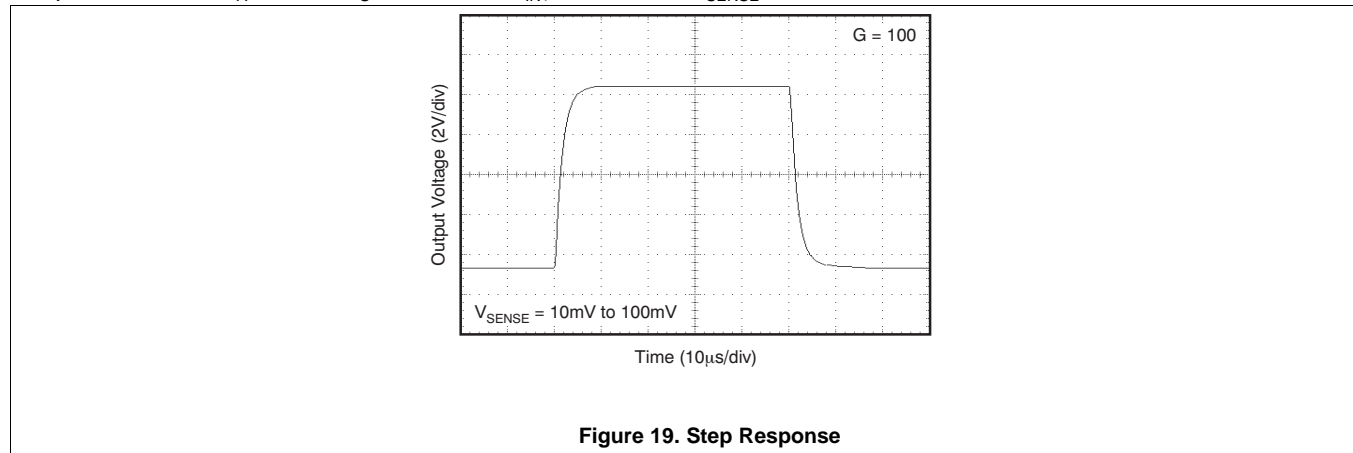

Figure 19. Step Response

## 8 Detailed Description

### 8.1 Overview

The INA193–INA198 family of current shunt monitors with voltage output can sense drops across shunts at common-mode voltages from  $-16\text{ V}$  to  $+80\text{ V}$ , independent of the INA19x supply voltage. They are available with three output voltage scales: 20 V/V, 50 V/V, and 100 V/V. The 500-kHz bandwidth simplifies use in current control loops. The INA193–INA195 devices provide identical functions but alternative pin configurations to the INA196–INA198, respectively.

The INA193–INA198 devices operate from a single  $+2.7\text{-V}$  to  $+18\text{-V}$  supply, drawing a maximum of  $900\text{ }\mu\text{A}$  of supply current. They are specified over the extended operating temperature range ( $-40^\circ\text{C}$  to  $+125^\circ\text{C}$ ), and are offered in a space-saving SOT-23 package.

### 8.2 Functional Block Diagram

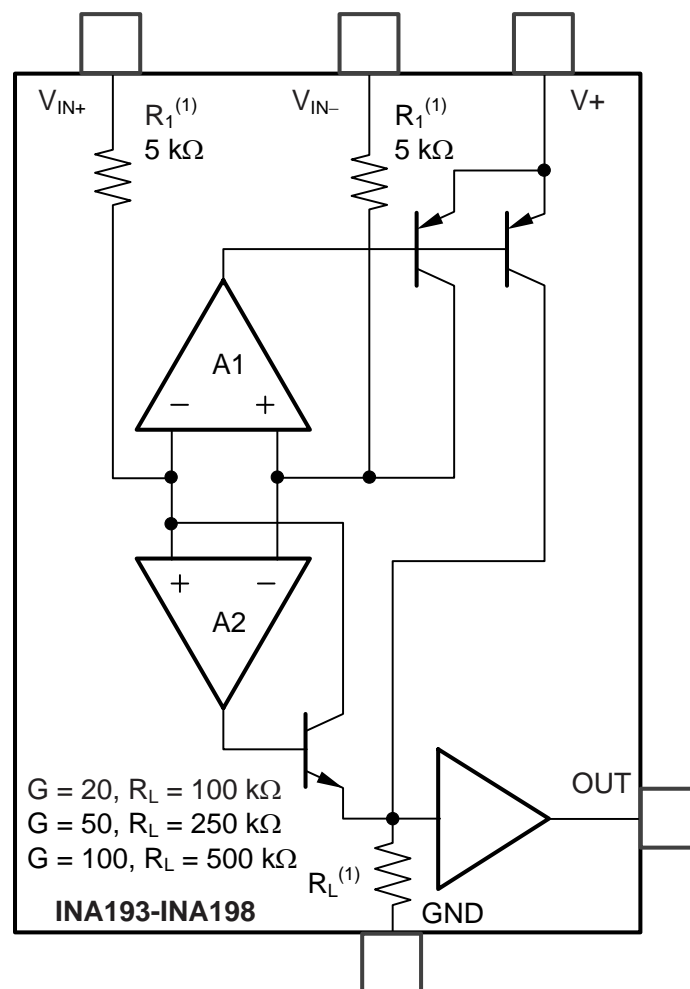

## 8.3 Feature Description

### 8.3.1 Basic Connection

Figure 20 shows the basic connection of the INA193-INA198. To minimize any resistance in series with the shunt resistor, connect the input pins,  $V_{IN+}$  and  $V_{IN-}$ , as closely as possible to the shunt resistor.

Power-supply bypass capacitors are required for stability. Applications with noisy or high impedance power supplies may require additional decoupling capacitors to reject power-supply noise. Connect bypass capacitors close to the device pins.

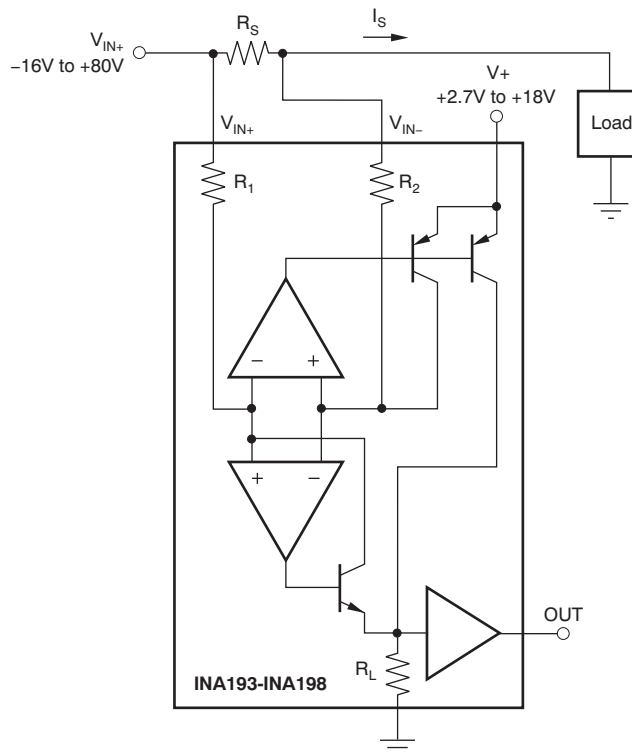

Figure 20. INA193-INA198 Basic Connection

### 8.3.2 Selecting $R_S$

The value chosen for the shunt resistor,  $R_S$ , depends on the application and is a compromise between small-signal accuracy and maximum permissible voltage loss in the measurement line. High values of  $R_S$  provide better accuracy at lower currents by minimizing the effects of offset, while low values of  $R_S$  minimize voltage loss in the supply line. For most applications, best performance is attained with an  $R_S$  value that provides a full-scale shunt voltage range of 50 mV to 100 mV. Maximum input voltage for accurate measurements is 500 mV.

### 8.3.3 Inside the INA193-INA198

The INA193-INA198 devices use a new, unique internal circuit topology that provides common-mode range extending from  $-16$  to  $80$  V while operating from a single power supply. The common-mode rejection in a classic instrumentation amplifier approach is limited by the requirement for accurate resistor matching. By converting the induced input voltage to a current, the INA193-INA198 devices provide common-mode rejection that is no longer a function of closely matched resistor values, providing the enhanced performance necessary for such a wide common-mode range. A simplified diagram (shown in Figure 21) shows the basic circuit function. When the common-mode voltage is positive, amplifier A2 is active.

**Feature Description (continued)**

The differential input voltage,  $(V_{IN+}) - (V_{IN-})$  applied across  $R_S$ , is converted to a current through a resistor. This current is converted back to a voltage through  $R_L$ , and then amplified by the output buffer amplifier. When the common-mode voltage is negative, amplifier A1 is active. The differential input voltage,  $(V_{IN+}) - (V_{IN-})$  applied across  $R_S$ , is converted to a current through a resistor. This current is sourced from a precision current mirror whose output is directed into  $R_L$  converting the signal back into a voltage and amplified by the output buffer amplifier. Patent-pending circuit architecture ensures smooth device operation, even during the transition period where both amplifiers A1 and A2 are active.

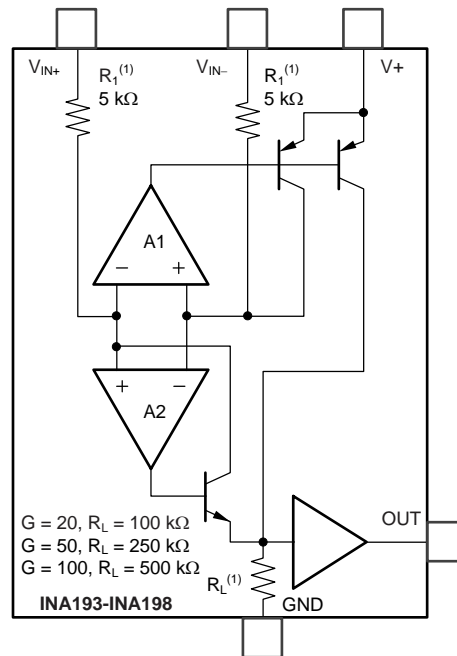

(1) Nominal resistor values are shown.  $\pm 15\%$  variation is possible. Resistor ratios are matched to  $\pm 1\%$ .

**Figure 21. INA193-INA198 Simplified Circuit Diagram**

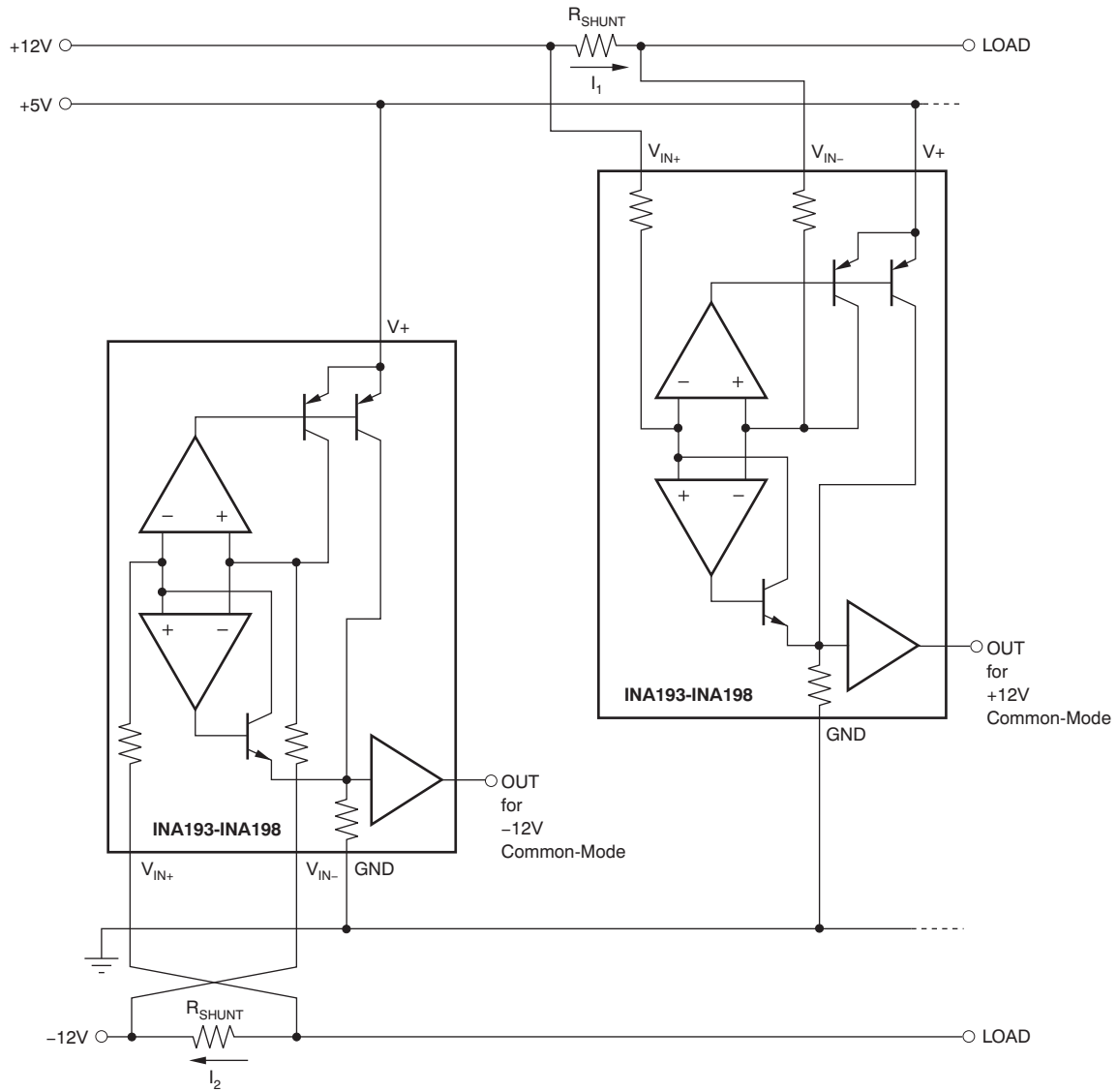

Figure 22. Monitor Bipolar Output Power-Supply Current

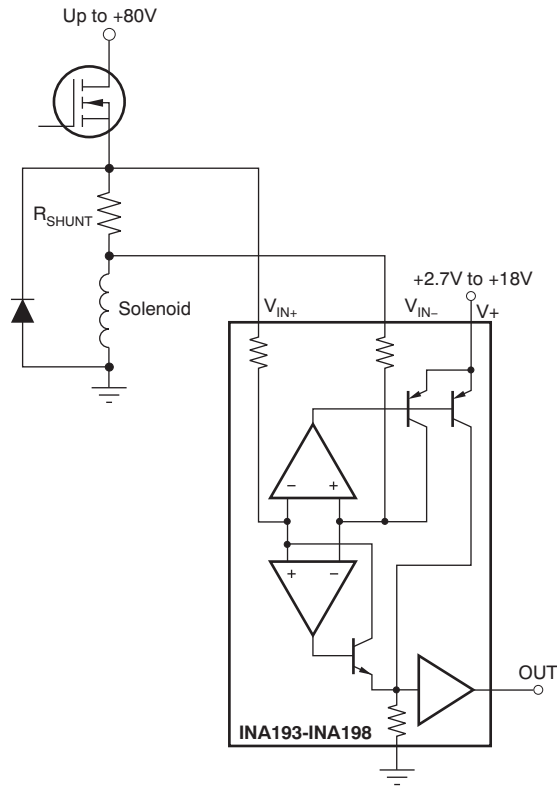
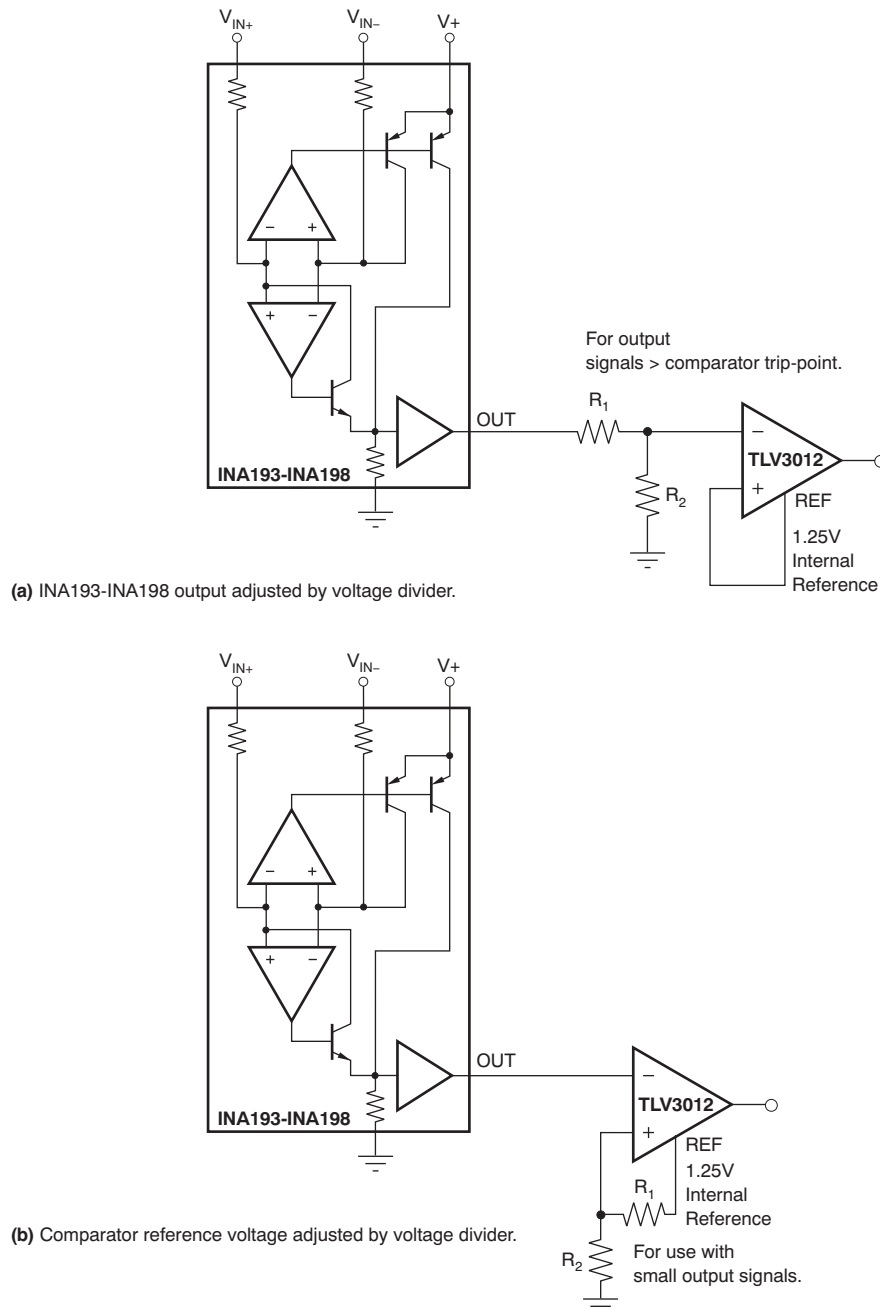

Figure 23. Inductive Current Monitor Including Flyback



(a) INA193-INA198 output adjusted by voltage divider.

(b) Comparator reference voltage adjusted by voltage divider.

Figure 24. INA193-INA198 with Comparator

## 8.4 Device Functional Modes

### 8.4.1 Input Filtering

An obvious and straightforward location for filtering is at the output of the INA193-INA198 devices; however, this location negates the advantage of the low output impedance of the internal buffer. The only other option for filtering is at the input pins of the INA193-INA198 devices, which is complicated by the internal 5-k $\Omega$  + 30% input impedance; this is illustrated in Figure 25. Using the lowest possible resistor values minimizes both the initial shift in gain and effects of tolerance. The effect on initial gain is given by Equation 1:



## Device Functional Modes (continued)

$$\text{GainError\%} = 100 - \left( \frac{5\text{k}\Omega}{5\text{k}\Omega + R_{\text{FILT}}} \right) \times 100 \quad (1)$$

Total effect on gain error can be calculated by replacing the 5-k $\Omega$  term with 5 k $\Omega$  – 30%, (or 3.5 k $\Omega$ ) or 5 k $\Omega$  + 30% (or 6.5 k $\Omega$ ). The tolerance extremes of  $R_{\text{FILT}}$  can also be inserted into the equation. If a pair of 100- $\Omega$  1% resistors are used on the inputs, the initial gain error will be approximately 2%. Worst-case tolerance conditions will always occur at the lower excursion of the internal 5-k $\Omega$  resistor (3.5 k $\Omega$ ), and the higher excursion of  $R_{\text{FILT}}$  – 3% in this case.

Note that the specified accuracy of the INA193-INA198 devices must then be combined in addition to these tolerances. While this discussion treated accuracy worst-case conditions by combining the extremes of the resistor values, it is appropriate to use geometric mean or root sum square calculations to total the effects of accuracy variations.

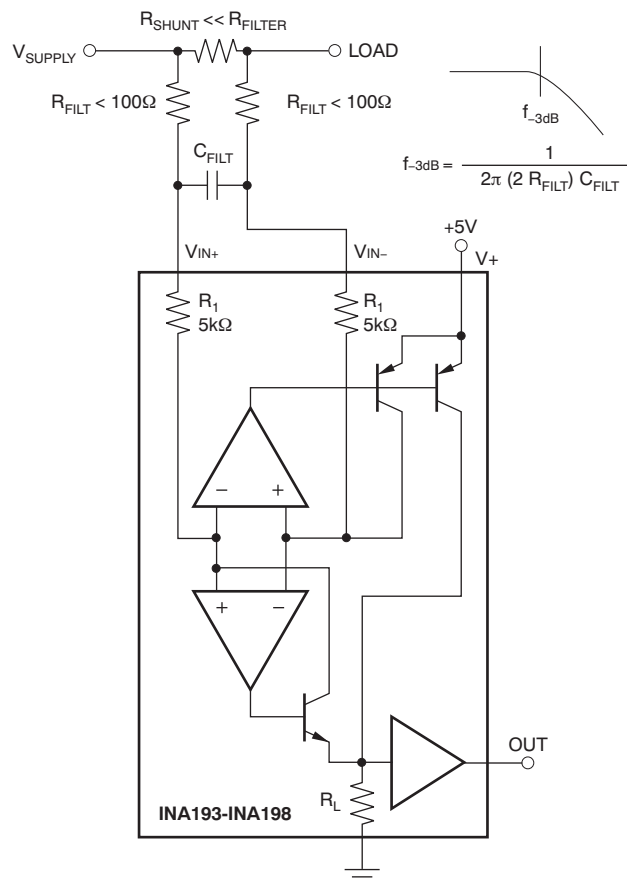

Figure 25. Input Filter (Gain Error – 1.5% To –2.2%)

### 8.4.2 Accuracy Variations as a Result of $V_{\text{SENSE}}$ and Common-Mode Voltage

The accuracy of the INA193–INA198 current shunt monitors is a function of two main variables:  $V_{\text{SENSE}}$  ( $V_{\text{IN+}} - V_{\text{IN-}}$ ) and common-mode voltage,  $V_{\text{CM}}$ , relative to the supply voltage,  $V_{\text{S}}$ .  $V_{\text{CM}}$  is expressed as  $(V_{\text{IN+}} + V_{\text{IN-}})/2$ ; however, in practice,  $V_{\text{CM}}$  is seen as the voltage at  $V_{\text{IN+}}$  because the voltage drop across  $V_{\text{SENSE}}$  is usually small.

This section addresses the accuracy of these specific operating regions:

- Normal Case 1:  $V_{\text{SENSE}} \geq 20\text{mV}$ ,  $V_{\text{CM}} \geq V_{\text{S}}$
- Normal Case 2:  $V_{\text{SENSE}} \geq 20\text{mV}$ ,  $V_{\text{CM}} < V_{\text{S}}$
- Low  $V_{\text{SENSE}}$  Case 1:  $V_{\text{SENSE}} < 20\text{mV}$ ,  $-16\text{V} \leq V_{\text{CM}} < 0$
- Low  $V_{\text{SENSE}}$  Case 2:  $V_{\text{SENSE}} < 20\text{mV}$ ,  $0\text{V} \leq V_{\text{CM}} \leq V_{\text{S}}$

## Device Functional Modes (continued)

Low  $V_{SENSE}$  Case 3:  $V_{SENSE} < 20\text{mV}$ ,  $V_S < V_{CM} \leq 80\text{V}$

### 8.4.2.1 Normal Case 1: $V_{SENSE} \geq 20\text{mV}$ , $V_{CM} \geq V_S$

This region of operation provides the highest accuracy. Here, the input offset voltage is characterized and measured using a two-step method. First, the gain is determined by [Equation 2](#).

$$G = \frac{V_{OUT1} - V_{OUT2}}{100\text{mV} - 20\text{mV}}$$

where:

$V_{OUT1}$  = Output Voltage with  $V_{SENSE} = 100\text{mV}$

$V_{OUT2}$  = Output Voltage with  $V_{SENSE} = 20\text{mV}$  (2)

Then the offset voltage is measured at  $V_{SENSE} = 100\text{mV}$  and referred to the input (RTI) of the current shunt monitor, as shown in [Equation 3](#).

$$V_{OS\text{RTI}} \text{ (Referred-To-Input)} = \left[ \frac{V_{OUT1}}{G} \right] - 100\text{mV} \quad (3)$$

In the [Typical Characteristics](#), the *Output Error vs Common-Mode Voltage* curve ([Figure 6](#)) shows the highest accuracy for this region of operation. In this plot,  $V_S = 12\text{V}$ ; for  $V_{CM} \geq 12\text{V}$ , the output error is at its minimum. This case is also used to create the  $V_{SENSE} \geq 20\text{-mV}$  output specifications in the [Electrical Characteristics](#) table.

### 8.4.2.2 Normal Case 2: $V_{SENSE} \geq 20\text{mV}$ , $V_{CM} < V_S$

This region of operation has slightly less accuracy than Normal Case 1 as a result of the common-mode operating area in which the part functions, as seen in the *Output Error vs Common-Mode Voltage* curve ([Figure 6](#)). As noted, for this graph  $V_S = 12\text{V}$ ; for  $V_{CM} < 12\text{V}$ , the Output Error increases as  $V_{CM}$  becomes less than  $12\text{V}$ , with a typical maximum error of 0.005% at the most negative  $V_{CM} = -16\text{V}$ .

## Device Functional Modes (continued)

### 8.4.2.3 Low $V_{SENSE}$ Case 1: $V_{SENSE} < 20\text{mV}$ , $-16\text{V} \leq V_{CM} < 0$ ; and Low $V_{SENSE}$ Case 3: $V_{SENSE} < 20\text{mV}$ , $V_S < V_{CM} \leq 80\text{V}$

Although the INA193–INA198 family of devices are not designed for accurate operation in either of these regions, some applications are exposed to these conditions; for example, when monitoring power supplies that are switched on and off while  $V_S$  is still applied to the INA193–INA198 devices. It is important to know what the behavior of the devices will be in these regions.

As  $V_{SENSE}$  approaches 0 mV, in these  $V_{CM}$  regions, the device output accuracy degrades. A larger-than-normal offset can appear at the current shunt monitor output with a typical maximum value of  $V_{OUT} = 300\text{ mV}$  for  $V_{SENSE} = 0\text{ mV}$ . As  $V_{SENSE}$  approaches 20 mV,  $V_{OUT}$  returns to the expected output value with accuracy as specified in the [Electrical Characteristics](#). Figure 26 illustrates this effect using the INA195 and INA198 devices (Gain = 100).

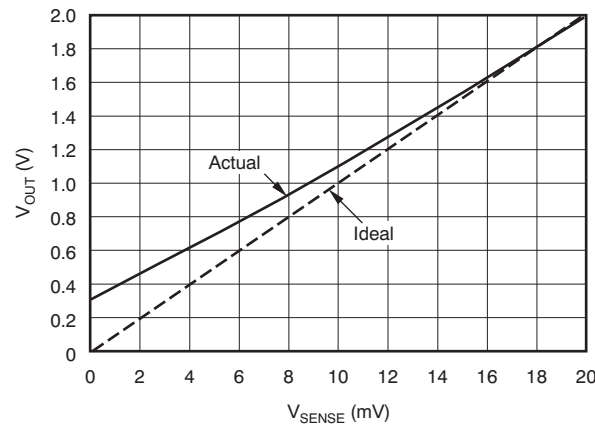
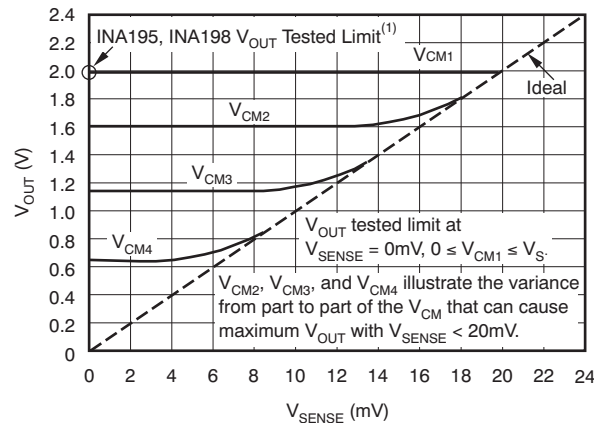

Figure 26. Example for Low  $V_{SENSE}$  Cases 1 and 3 (INA195, INA198: Gain = 100)

### 8.4.2.4 Low $V_{SENSE}$ Case 2: $V_{SENSE} < 20\text{ mV}$ , $0\text{ V} \leq V_{CM} \leq V_S$

This region of operation is the least accurate for the INA193–INA198 family of devices. To achieve the wide input common-mode voltage range, these devices use two op amp front ends in parallel. One op amp front end operates in the positive input common-mode voltage range, and the other in the negative input region. For this case, neither of these two internal amplifiers dominates and overall loop gain is very low. Within this region,  $V_{OUT}$  approaches voltages close to linear operation levels for Normal Case 2. This deviation from linear operation becomes greatest the closer  $V_{SENSE}$  approaches 0 V. Within this region, as  $V_{SENSE}$  approaches 20 mV, device operation is closer to that described by Normal Case 2. Figure 27 illustrates this behavior for the INA195 device. The  $V_{OUT}$  maximum peak for this case is tested by maintaining a constant  $V_S$ , setting  $V_{SENSE} = 0\text{ mV}$  and sweeping  $V_{CM}$  from 0 V to  $V_S$ . The exact  $V_{CM}$  at which  $V_{OUT}$  peaks during this test varies from part to part, but the  $V_{OUT}$  maximum peak is tested to be less than the specified  $V_{OUT}$  Tested Limit.

## Device Functional Modes (continued)



(1) INA193, INA196  $V_{OUT}$  Tested Limit = 0.4V. INA194, INA197  $V_{OUT}$  Tested Limit = 1V.

**Figure 27. Example for Low  $V_{SENSE}$  Case 2 (INA195, INA198: Gain = 100)**

### 8.4.3 Shutdown

Because the INA193-INA198 devices consume a quiescent current less than 1 mA, they can be powered by either the output of logic gates or by transistor switches to supply power. Use a totem-pole output buffer or gate that can provide sufficient drive along with 0.1- $\mu$ F bypass capacitor, preferably ceramic with good high-frequency characteristics. This gate should have a supply voltage of 3 V or greater because the INA193-INA198 devices require a minimum supply greater than 2.7 V. In addition to eliminating quiescent current, this gate also turns off the 10- $\mu$ A bias current present at each of the inputs. An example shutdown circuit is shown in Figure 28.

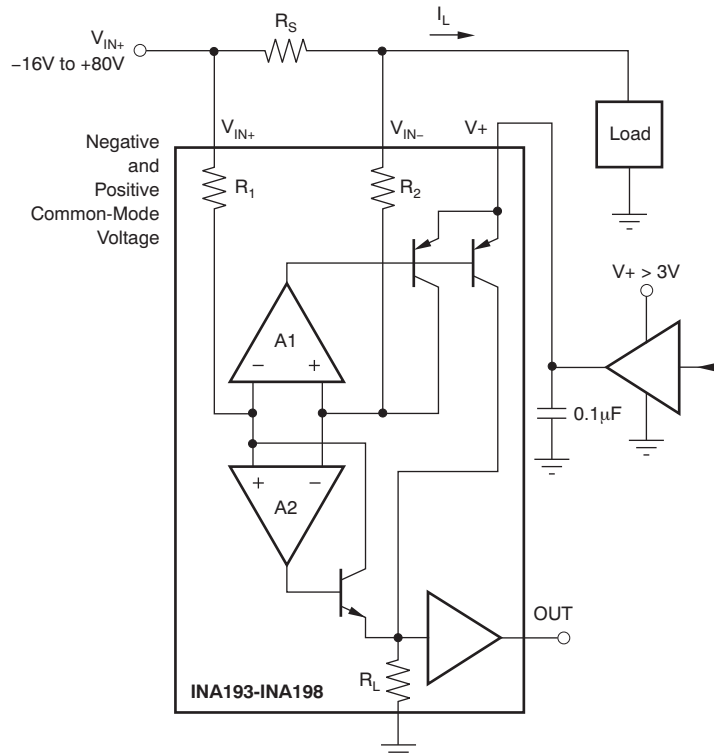

**Figure 28. INA193-INA198 Example Shutdown Circuit**

## Device Functional Modes (continued)

### 8.4.4 Transient Protection

The  $-16\text{-V}$  to  $+80\text{-V}$  common-mode range of the INA193-INA198 devices is ideal for withstanding automotive fault conditions ranging from 12-V battery reversal up to 80-V transients, since no additional protective components are needed up to those levels. In the event that the INA193-INA198 devices are exposed to transients on the inputs in excess of its ratings, then external transient absorption with semiconductor transient absorbers (zeners or Transzorbs) will be necessary. Use of MOVs or VDRs is not recommended except when they are used in addition to a semiconductor transient absorber. Select the transient absorber such that it will never allow the INA193-INA198 devices to be exposed to transients greater than  $+80\text{ V}$  (that is, allow for transient absorber tolerance, as well as additional voltage due to transient absorber dynamic impedance). Despite the use of internal zener-type ESD protection, the INA193-INA198 devices do not lend themselves to using external resistors in series with the inputs because the internal gain resistors can vary up to  $\pm 30\%$ . (If gain accuracy is not important, then resistors can be added in series with the INA193-INA198 inputs with two equal resistors on each input.)

### 8.4.5 Output Voltage Range

The output of the INA193-INA198 devices are accurate within the output voltage swing range set by the power-supply pin,  $V+$ . This is best illustrated when using the INA195 or INA198 devices (which are both versions using a gain of 100), where a 100-mV full-scale input from the shunt resistor requires an output voltage swing of  $+10\text{ V}$ , and a power-supply voltage sufficient to achieve  $+10\text{ V}$  on the output.

## 9 Application and Implementation

### NOTE

Information in the following applications sections is not part of the TI component specification, and TI does not warrant its accuracy or completeness. TI's customers are responsible for determining suitability of components for their purposes. Customers should validate and test their design implementation to confirm system functionality.

### 9.1 Application Information

The INA193-INA198 devices measure the voltage developed across a current-sensing resistor when current passes through it. The ability to have shunt common-mode voltages from  $-16\text{-V}$  to  $+80\text{-V}$  drive and control the output signal with  $V_S$  offers multiple configurations, as discussed throughout this section.

### 9.2 Typical Application

The device is a unidirectional, current-sense amplifier capable of measuring currents through a resistive shunt with shunt common-mode voltages from  $-16\text{ V}$  to  $80\text{ V}$ . Two devices can be configured for bidirectional monitoring and is common in applications that include charging and discharging operations where the current flow-through resistor can change directions.

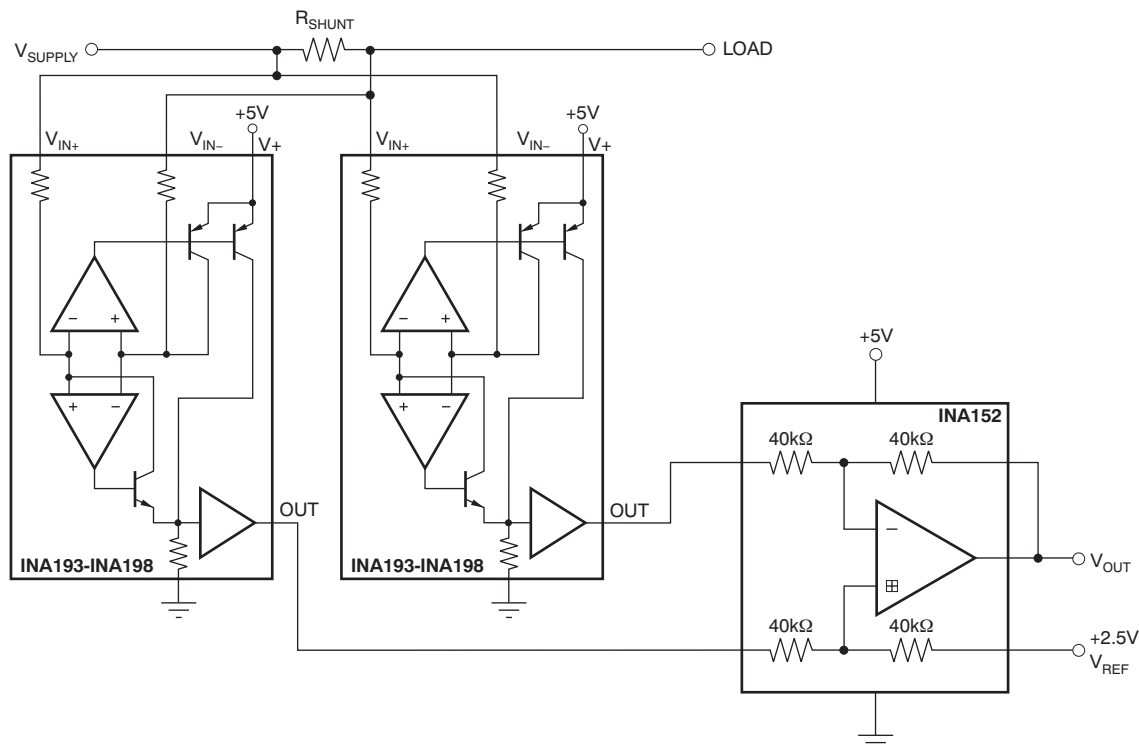

Figure 29. Bi-Directional Current Monitoring

#### 9.2.1 Design Requirements

$V_{supply}$  is set to  $12\text{ V}$ ,  $V_{ref}$  at  $2.5\text{ V}$  and a  $10\text{-m}\Omega$  shunt. The accuracy of the current will typically be less than  $0.5\%$  for current greater than  $\pm 2\text{ A}$ . For current lower than  $\pm 2\text{ A}$ , the accuracy will vary; use the [Device Functional Modes](#) section for accuracy considerations.

## Typical Application (continued)

### 9.2.2 Detailed Design Procedure

The ability to measure this current flowing in both directions is enabled by adding a unity gain amplifier with a  $V_{REF}$ , as shown in Figure 29. The output then responds by increasing above  $V_{REF}$  for positive differential signals (relative to the  $IN -$  pin) and responds by decreasing below  $V_{REF}$  for negative differential signals. This reference voltage applied to the REF pin can be set anywhere between 0 V to  $V+$ . For bidirectional applications,  $V_{REF}$  is typically set at mid-scale for equal signal range in both current directions. In some cases, however,  $V_{REF}$  is set at a voltage other than mid-scale when the bidirectional current and corresponding output signal do not need to be symmetrical.

### 9.2.3 Application Curve

An example output response of a bidirectional configuration is shown in Figure 30. With the REF pin connected to a reference voltage, 2.5 V in this case, the output voltage is biased upwards by this reference level. The output rises above the reference voltage for positive differential input signals and falls below the reference voltage for negative differential input signals.

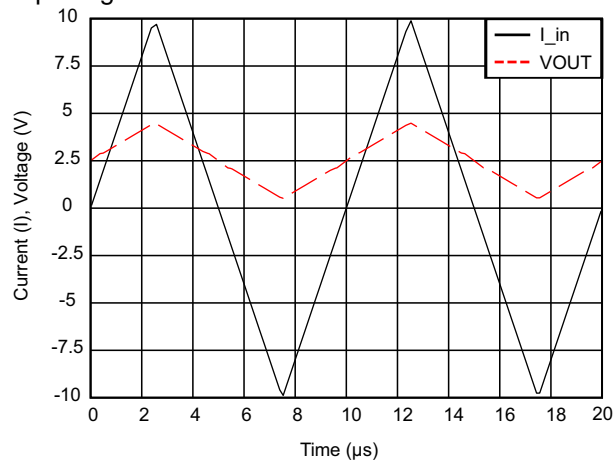

Figure 30. Output Voltage vs Shunt Input Current

## 10 Power Supply Recommendations

The input circuitry of the INA193-INA198 devices can accurately measure beyond its power-supply voltage,  $V+$ . For example, the  $V+$  power supply can be 5 V, whereas the load power-supply voltage is up to 80 V. The output voltage range of the OUT terminal, however, is limited by the voltages on the power-supply pin.

## 11 Layout

### 11.1 Layout Guidelines

#### 11.1.1 RFI and EMI

Attention to good layout practices is always recommended. Keep traces short and, when possible, use a printed circuit board (PCB) ground plane with surface-mount components placed as close to the device pins as possible. Small ceramic capacitors placed directly across amplifier inputs can reduce RFI/EMI sensitivity. PCB layout should locate the amplifier as far away as possible from RFI sources. Sources can include other components in the same system as the amplifier itself, such as inductors (particularly switched inductors handling a lot of current and at high frequencies). RFI can generally be identified as a variation in offset voltage or DC signal levels with changes in the interfering RF signal. If the amplifier cannot be located away from sources of radiation, shielding may be needed. Twisting wire input leads makes them more resistant to RF fields. The difference in input pin location of the INA193-INA195 devices versus the INA196-INA198 devices may provide different EMI performance.

## 11.2 Layout Example

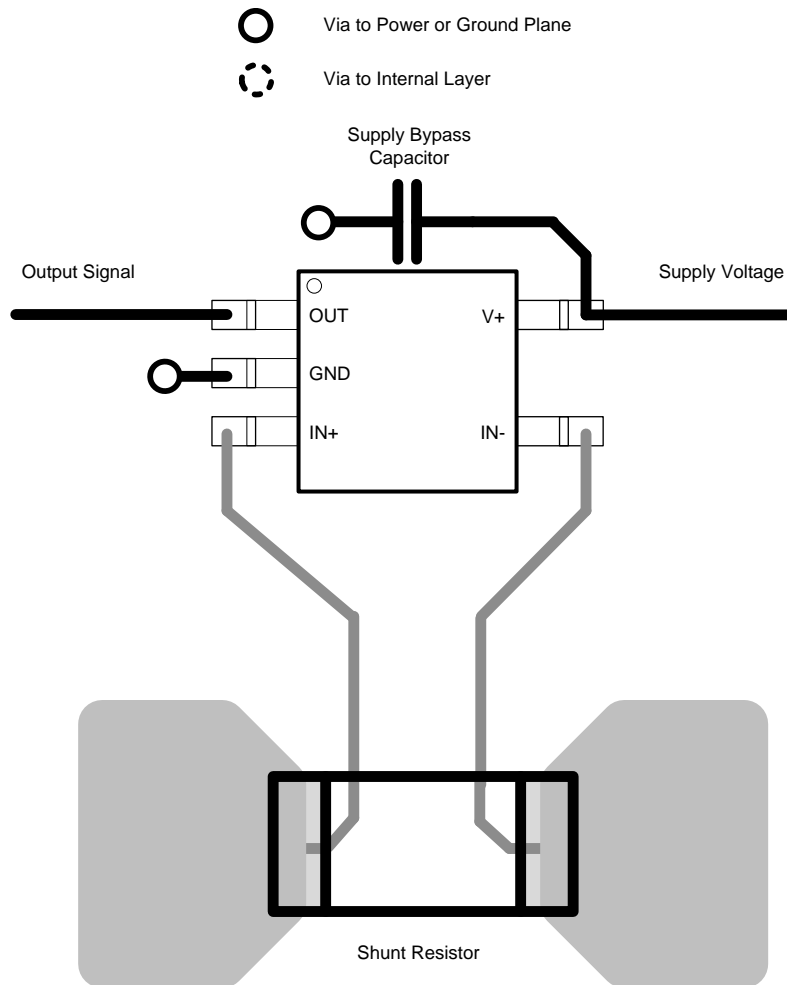

Figure 31. Recommended Layout



## 12 Device and Documentation Support

### 12.1 Related Links

The table below lists quick access links. Categories include technical documents, support and community resources, tools and software, and quick access to sample or buy.

**Table 1. Related Links**

PARTS	PRODUCT FOLDER	SAMPLE & BUY	TECHNICAL DOCUMENTS	TOOLS & SOFTWARE	SUPPORT & COMMUNITY
INA193	<a href="#">Click here</a>	<a href="#">Click here</a>	<a href="#">Click here</a>	<a href="#">Click here</a>	<a href="#">Click here</a>
INA194	<a href="#">Click here</a>	<a href="#">Click here</a>	<a href="#">Click here</a>	<a href="#">Click here</a>	<a href="#">Click here</a>
INA195	<a href="#">Click here</a>	<a href="#">Click here</a>	<a href="#">Click here</a>	<a href="#">Click here</a>	<a href="#">Click here</a>
INA196	<a href="#">Click here</a>	<a href="#">Click here</a>	<a href="#">Click here</a>	<a href="#">Click here</a>	<a href="#">Click here</a>
INA197	<a href="#">Click here</a>	<a href="#">Click here</a>	<a href="#">Click here</a>	<a href="#">Click here</a>	<a href="#">Click here</a>
INA198	<a href="#">Click here</a>	<a href="#">Click here</a>	<a href="#">Click here</a>	<a href="#">Click here</a>	<a href="#">Click here</a>

### 12.2 Trademarks

All trademarks are the property of their respective owners.

### 12.3 Electrostatic Discharge Caution



These devices have limited built-in ESD protection. The leads should be shorted together or the device placed in conductive foam during storage or handling to prevent electrostatic damage to the MOS gates.

### 12.4 Glossary

[SLYZ022](#) — *TI Glossary*.

This glossary lists and explains terms, acronyms, and definitions.

## 13 Mechanical, Packaging, and Orderable Information

The following pages include mechanical, packaging, and orderable information. This information is the most current data available for the designated devices. This data is subject to change without notice and revision of this document. For browser-based versions of this data sheet, refer to the left-hand navigation.

**PACKAGING INFORMATION**

Orderable Device	Status (1)	Package Type	Package Drawing	Pins	Package Qty	Eco Plan (2)	Lead finish/ Ball material (6)	MSL Peak Temp (3)	Op Temp (°C)	Device Marking (4/5)	Samples
INA193AIDBVR	ACTIVE	SOT-23	DBV	5	3000	RoHS & Green	NIPDAU	Level-2-260C-1 YEAR	-40 to 125	BJJ	<a href="#">Samples</a>
INA193AIDBVT	ACTIVE	SOT-23	DBV	5	250	RoHS & Green	NIPDAU	Level-2-260C-1 YEAR	-40 to 125	BJJ	<a href="#">Samples</a>
INA194AIDBVR	ACTIVE	SOT-23	DBV	5	3000	RoHS & Green	NIPDAU   SN	Level-2-260C-1 YEAR	-40 to 125	BJI	<a href="#">Samples</a>
INA194AIDBVRG4	LIFEBUY	SOT-23	DBV	5	3000	RoHS & Green	NIPDAU	Level-2-260C-1 YEAR	-40 to 125	BJI	
INA194AIDBVT	ACTIVE	SOT-23	DBV	5	250	RoHS & Green	NIPDAU   SN	Level-2-260C-1 YEAR	-40 to 125	BJI	<a href="#">Samples</a>
INA194AIDBVTG4	LIFEBUY	SOT-23	DBV	5	250	RoHS & Green	NIPDAU	Level-2-260C-1 YEAR	-40 to 125	BJI	
INA195AIDBVR	ACTIVE	SOT-23	DBV	5	3000	RoHS & Green	NIPDAU	Level-2-260C-1 YEAR	-40 to 125	BJK	<a href="#">Samples</a>
INA195AIDBVT	ACTIVE	SOT-23	DBV	5	250	RoHS & Green	NIPDAU	Level-2-260C-1 YEAR	-40 to 125	BJK	<a href="#">Samples</a>
INA195AIDBVTG4	LIFEBUY	SOT-23	DBV	5	250	RoHS & Green	NIPDAU	Level-2-260C-1 YEAR	-40 to 125	BJK	
INA196AIDBVR	ACTIVE	SOT-23	DBV	5	3000	RoHS & Green	NIPDAU	Level-2-260C-1 YEAR	-40 to 125	BJE	<a href="#">Samples</a>
INA196AIDBVRG4	LIFEBUY	SOT-23	DBV	5	3000	RoHS & Green	NIPDAU	Level-2-260C-1 YEAR	-40 to 125	BJE	
INA196AIDBVT	ACTIVE	SOT-23	DBV	5	250	RoHS & Green	NIPDAU	Level-2-260C-1 YEAR	-40 to 125	BJE	<a href="#">Samples</a>
INA196AIDBVTG4	LIFEBUY	SOT-23	DBV	5	250	RoHS & Green	NIPDAU	Level-2-260C-1 YEAR	-40 to 125	BJE	
INA197AIDBVR	ACTIVE	SOT-23	DBV	5	3000	RoHS & Green	NIPDAU	Level-2-260C-1 YEAR	-40 to 125	BJH	<a href="#">Samples</a>
INA197AIDBVT	ACTIVE	SOT-23	DBV	5	250	RoHS & Green	NIPDAU	Level-2-260C-1 YEAR	-40 to 125	BJH	<a href="#">Samples</a>
INA198AIDBVR	ACTIVE	SOT-23	DBV	5	3000	RoHS & Green	NIPDAU	Level-2-260C-1 YEAR	-40 to 125	BJL	<a href="#">Samples</a>
INA198AIDBVT	ACTIVE	SOT-23	DBV	5	250	RoHS & Green	NIPDAU	Level-2-260C-1 YEAR	-40 to 125	BJL	<a href="#">Samples</a>
INA198AIDBVTG4	LIFEBUY	SOT-23	DBV	5	250	RoHS & Green	NIPDAU	Level-2-260C-1 YEAR	-40 to 125	BJL	

(1) The marketing status values are defined as follows:

**ACTIVE:** Product device recommended for new designs.

**LIFEBUY:** TI has announced that the device will be discontinued, and a lifetime-buy period is in effect.

**NRND:** Not recommended for new designs. Device is in production to support existing customers, but TI does not recommend using this part in a new design.

**PREVIEW:** Device has been announced but is not in production. Samples may or may not be available.

**OBSOLETE:** TI has discontinued the production of the device.

(2) **RoHS:** TI defines "RoHS" to mean semiconductor products that are compliant with the current EU RoHS requirements for all 10 RoHS substances, including the requirement that RoHS substance do not exceed 0.1% by weight in homogeneous materials. Where designed to be soldered at high temperatures, "RoHS" products are suitable for use in specified lead-free processes. TI may reference these types of products as "Pb-Free".

**RoHS Exempt:** TI defines "RoHS Exempt" to mean products that contain lead but are compliant with EU RoHS pursuant to a specific EU RoHS exemption.

**Green:** TI defines "Green" to mean the content of Chlorine (Cl) and Bromine (Br) based flame retardants meet JS709B low halogen requirements of  $\leq 1000$ ppm threshold. Antimony trioxide based flame retardants must also meet the  $\leq 1000$ ppm threshold requirement.

(3) **MSL, Peak Temp.** - The Moisture Sensitivity Level rating according to the JEDEC industry standard classifications, and peak solder temperature.

(4) There may be additional marking, which relates to the logo, the lot trace code information, or the environmental category on the device.

(5) Multiple Device Markings will be inside parentheses. Only one Device Marking contained in parentheses and separated by a "~" will appear on a device. If a line is indented then it is a continuation of the previous line and the two combined represent the entire Device Marking for that device.

(6) **Lead finish/Ball material** - Orderable Devices may have multiple material finish options. Finish options are separated by a vertical ruled line. Lead finish/Ball material values may wrap to two lines if the finish value exceeds the maximum column width.

**Important Information and Disclaimer:**The information provided on this page represents TI's knowledge and belief as of the date that it is provided. TI bases its knowledge and belief on information provided by third parties, and makes no representation or warranty as to the accuracy of such information. Efforts are underway to better integrate information from third parties. TI has taken and continues to take reasonable steps to provide representative and accurate information but may not have conducted destructive testing or chemical analysis on incoming materials and chemicals. TI and TI suppliers consider certain information to be proprietary, and thus CAS numbers and other limited information may not be available for release.

In no event shall TI's liability arising out of such information exceed the total purchase price of the TI part(s) at issue in this document sold by TI to Customer on an annual basis.

**TAPE AND REEL INFORMATION**

**QUADRANT ASSIGNMENTS FOR PIN 1 ORIENTATION IN TAPE**

\*All dimensions are nominal

Device	Package Type	Package Drawing	Pins	SPQ	Reel Diameter (mm)	Reel Width W1 (mm)	A0 (mm)	B0 (mm)	K0 (mm)	P1 (mm)	W (mm)	Pin1 Quadrant
INA193AIDBVR	SOT-23	DBV	5	3000	178.0	9.0	3.23	3.17	1.37	4.0	8.0	Q3
INA193AIDBVT	SOT-23	DBV	5	250	178.0	9.0	3.3	3.2	1.4	4.0	8.0	Q3
INA194AIDBVR	SOT-23	DBV	5	3000	178.0	9.0	3.23	3.17	1.37	4.0	8.0	Q3
INA194AIDBVT	SOT-23	DBV	5	250	178.0	9.0	3.3	3.2	1.4	4.0	8.0	Q3
INA195AIDBVR	SOT-23	DBV	5	3000	178.0	9.0	3.3	3.2	1.4	4.0	8.0	Q3
INA195AIDBVT	SOT-23	DBV	5	250	178.0	9.0	3.3	3.2	1.4	4.0	8.0	Q3
INA196AIDBVR	SOT-23	DBV	5	3000	178.0	9.0	3.3	3.2	1.4	4.0	8.0	Q3
INA196AIDBVT	SOT-23	DBV	5	250	178.0	9.0	3.3	3.2	1.4	4.0	8.0	Q3
INA197AIDBVR	SOT-23	DBV	5	3000	178.0	9.0	3.3	3.2	1.4	4.0	8.0	Q3
INA197AIDBVT	SOT-23	DBV	5	250	178.0	9.0	3.3	3.2	1.4	4.0	8.0	Q3
INA198AIDBVR	SOT-23	DBV	5	3000	178.0	9.0	3.3	3.2	1.4	4.0	8.0	Q3
INA198AIDBVT	SOT-23	DBV	5	250	178.0	9.0	3.3	3.2	1.4	4.0	8.0	Q3

**TAPE AND REEL BOX DIMENSIONS**

\*All dimensions are nominal

Device	Package Type	Package Drawing	Pins	SPQ	Length (mm)	Width (mm)	Height (mm)
INA193AIDBVR	SOT-23	DBV	5	3000	180.0	180.0	18.0
INA193AIDBVT	SOT-23	DBV	5	250	180.0	180.0	18.0
INA194AIDBVR	SOT-23	DBV	5	3000	180.0	180.0	18.0
INA194AIDBVT	SOT-23	DBV	5	250	180.0	180.0	18.0
INA195AIDBVR	SOT-23	DBV	5	3000	180.0	180.0	18.0
INA195AIDBVT	SOT-23	DBV	5	250	180.0	180.0	18.0
INA196AIDBVR	SOT-23	DBV	5	3000	180.0	180.0	18.0
INA196AIDBVT	SOT-23	DBV	5	250	180.0	180.0	18.0
INA197AIDBVR	SOT-23	DBV	5	3000	180.0	180.0	18.0
INA197AIDBVT	SOT-23	DBV	5	250	180.0	180.0	18.0
INA198AIDBVR	SOT-23	DBV	5	3000	180.0	180.0	18.0
INA198AIDBVT	SOT-23	DBV	5	250	180.0	180.0	18.0

# DBV0005A



# PACKAGE OUTLINE

SOT-23 - 1.45 mm max height

SMALL OUTLINE TRANSISTOR



## NOTES:

1. All linear dimensions are in millimeters. Any dimensions in parenthesis are for reference only. Dimensioning and tolerancing per ASME Y14.5M.
2. This drawing is subject to change without notice.
3. Reference JEDEC MO-178.
4. Body dimensions do not include mold flash, protrusions, or gate burrs. Mold flash, protrusions, or gate burrs shall not exceed 0.25 mm per side.
5. Support pin may differ or may not be present.

# EXAMPLE BOARD LAYOUT

DBV0005A

SOT-23 - 1.45 mm max height

SMALL OUTLINE TRANSISTOR



LAND PATTERN EXAMPLE  
EXPOSED METAL SHOWN  
SCALE:15X



SOLDER MASK DETAILS

4214839/H 09/2023

NOTES: (continued)

- 6. Publication IPC-7351 may have alternate designs.
- 7. Solder mask tolerances between and around signal pads can vary based on board fabrication site.

# EXAMPLE STENCIL DESIGN

DBV0005A

SOT-23 - 1.45 mm max height

SMALL OUTLINE TRANSISTOR



SOLDER PASTE EXAMPLE  
BASED ON 0.125 mm THICK STENCIL  
SCALE:15X

4214839/H 09/2023

NOTES: (continued)

8. Laser cutting apertures with trapezoidal walls and rounded corners may offer better paste release. IPC-7525 may have alternate design recommendations.
9. Board assembly site may have different recommendations for stencil design.



## IMPORTANT NOTICE AND DISCLAIMER

TI PROVIDES TECHNICAL AND RELIABILITY DATA (INCLUDING DATA SHEETS), DESIGN RESOURCES (INCLUDING REFERENCE DESIGNS), APPLICATION OR OTHER DESIGN ADVICE, WEB TOOLS, SAFETY INFORMATION, AND OTHER RESOURCES "AS IS" AND WITH ALL FAULTS, AND DISCLAIMS ALL WARRANTIES, EXPRESS AND IMPLIED, INCLUDING WITHOUT LIMITATION ANY IMPLIED WARRANTIES OF MERCHANTABILITY, FITNESS FOR A PARTICULAR PURPOSE OR NON-INFRINGEMENT OF THIRD PARTY INTELLECTUAL PROPERTY RIGHTS.

These resources are intended for skilled developers designing with TI products. You are solely responsible for (1) selecting the appropriate TI products for your application, (2) designing, validating and testing your application, and (3) ensuring your application meets applicable standards, and any other safety, security, regulatory or other requirements.

These resources are subject to change without notice. TI grants you permission to use these resources only for development of an application that uses the TI products described in the resource. Other reproduction and display of these resources is prohibited. No license is granted to any other TI intellectual property right or to any third party intellectual property right. TI disclaims responsibility for, and you will fully indemnify TI and its representatives against, any claims, damages, costs, losses, and liabilities arising out of your use of these resources.

TI's products are provided subject to [TI's Terms of Sale](#) or other applicable terms available either on [ti.com](https://www.ti.com) or provided in conjunction with such TI products. TI's provision of these resources does not expand or otherwise alter TI's applicable warranties or warranty disclaimers for TI products.

TI objects to and rejects any additional or different terms you may have proposed.

Mailing Address: Texas Instruments, Post Office Box 655303, Dallas, Texas 75265  
Copyright © 2023, Texas Instruments Incorporated