

記号x数	変更内容	REVISION DESCRIPTION	承認	検図	担当	年月日	変更通知書No.
△ x							
△ x							
△ x							
△ x							
△ x							

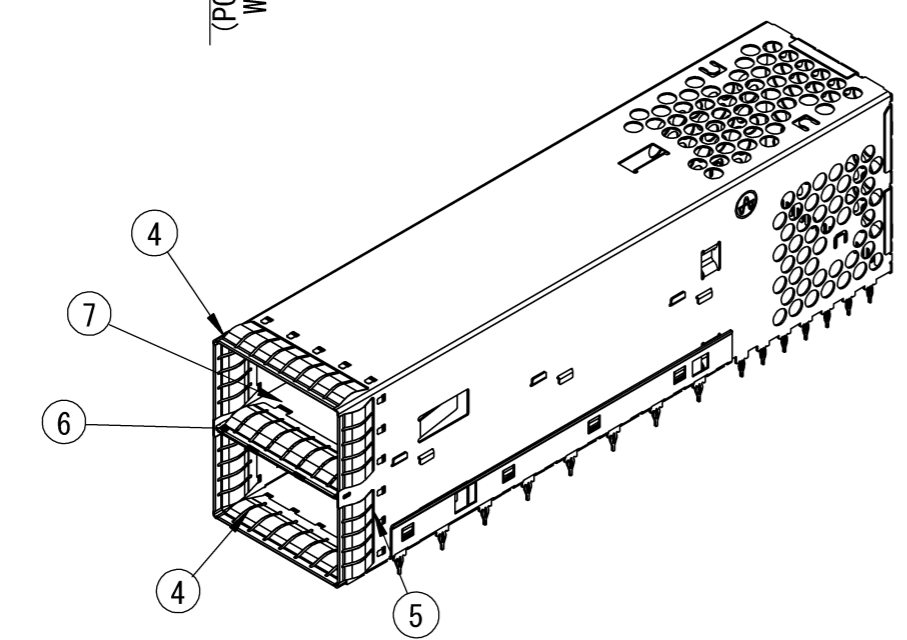
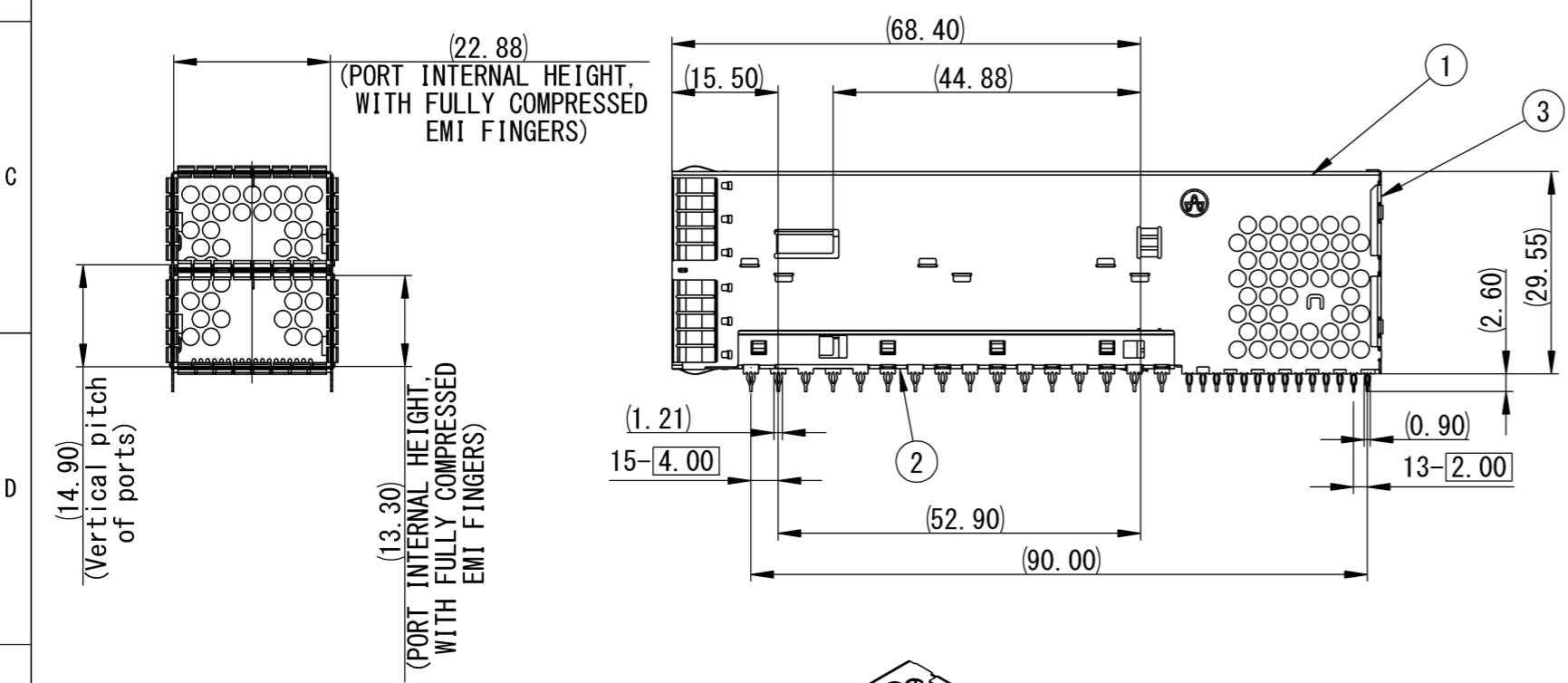
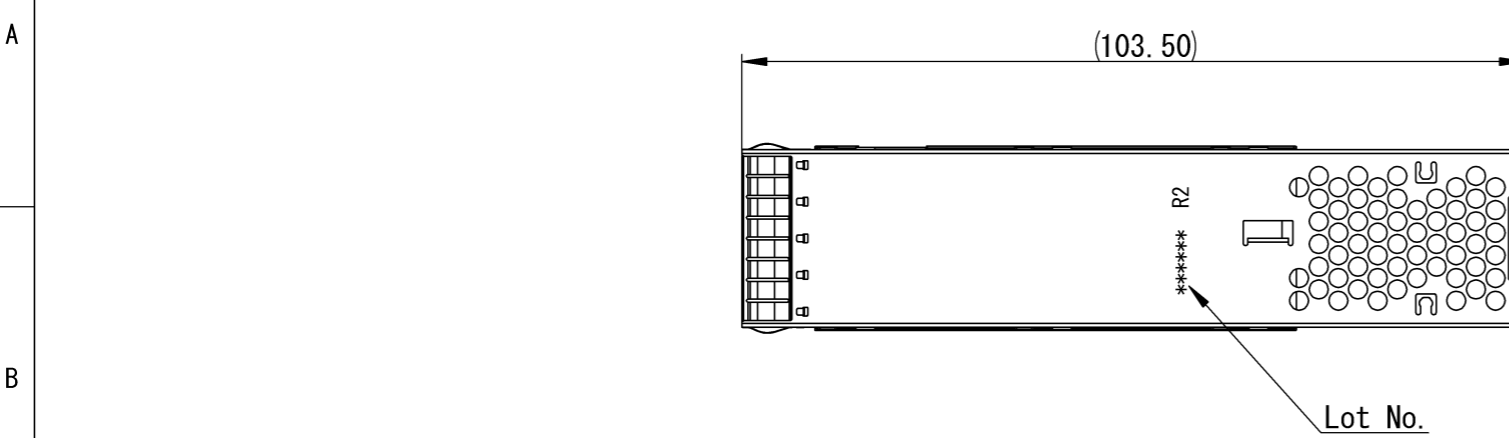

記事 NOTE

- 性能・取り扱いは仕様書 (F121582-001) による。
Performance and handling shall conform to the Specification (F121582-001).
- 標準梱包はトレイとする。(梱包仕様書 R121968-001)
Standard packaging shall be Tray packing.
Refer to Packaging Spec. R121968-001 for details.
- Lot No.
Lot No. : ***** R2

Revision(Drawing will be revised when the design changed)

Date of manufacture(yymmdd)

部品番号 ITEM	部品名 DISRIPTION	個数 QNT.	材料 MATERIAL	寸法 DIMENSION	記事 CONTENT
7	Partition	2	Stainless steel		Degreasing
6	EMI-Finger Center	1	Stainless steel		Degreasing
5	EMI-Finger Side	4	Stainless steel		Degreasing
4	EMI-Finger Top/Bottom	2	Stainless steel		Degreasing
3	Rear Cage	1	Stainless steel		Degreasing
2	Bottom Cage	1	Stainless steel		Degreasing
1	Outer Cage	1	Stainless steel		Degreasing

2021/12/14 15:54 電機株式会社
YAMAICHI ELECTRONICS Co.,Ltd.
山一電機(株)
OSFP STACK CAGE

指定外公差 ±0.3
Tolerances ±0.3 unless otherwise specified.
()寸法は参考値 ()Reference value.

尺度 SCALE	1 / 1	承認 APP.	承認 APP.	検図 CHK.	製図 DRW.	設計 DSGN.	名称 (TITLE)
単位 DIMENSION	mm	20/12/24	20/12/24	20/12/23	20/12/17	20/12/17	CN176D-1002-01
三角図法 3RD. ANGLE PROJECTION		伊東	佐藤	高居	圓城寺	圓城寺	図番 (DRW. NO.) A121968-001

Sheet No. 1/2 REV. A

PCB LAYOUT

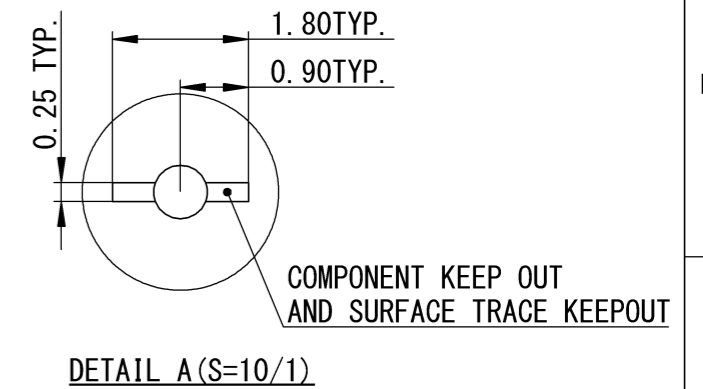
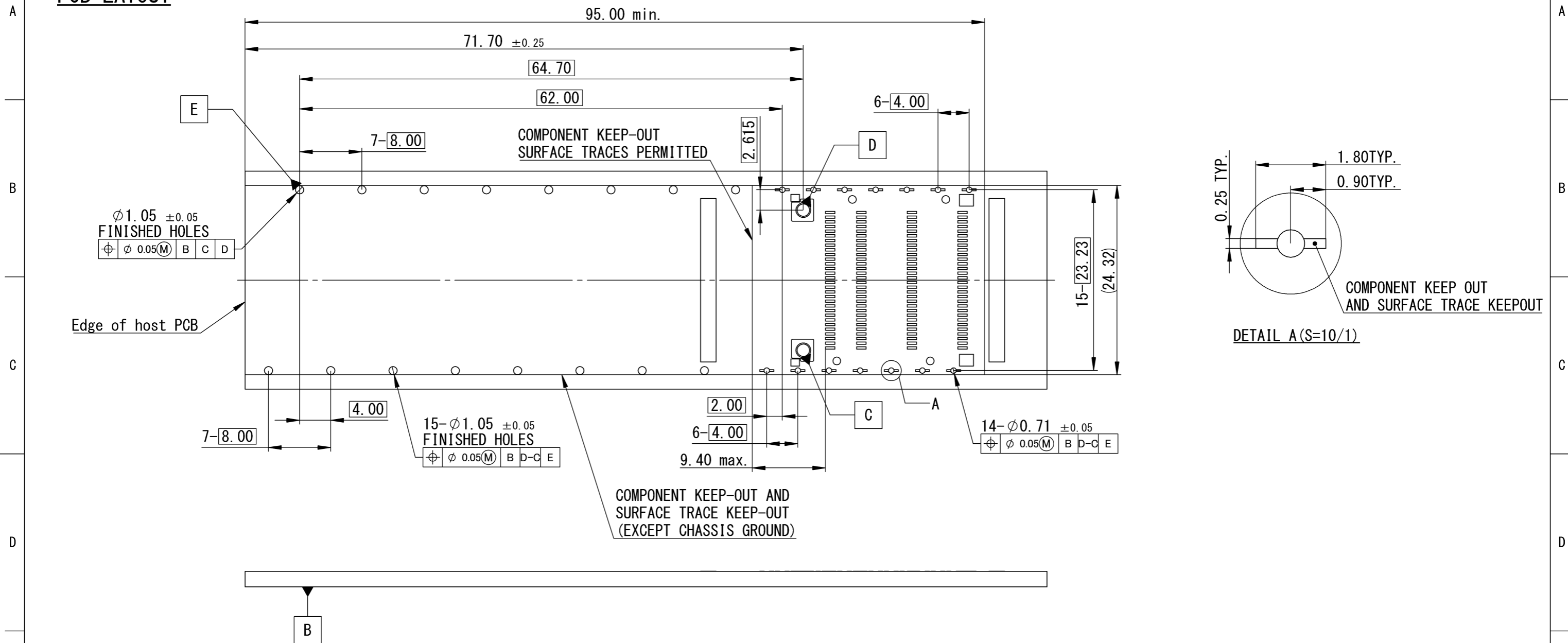

PANEL DIMENSION (S=1/1)

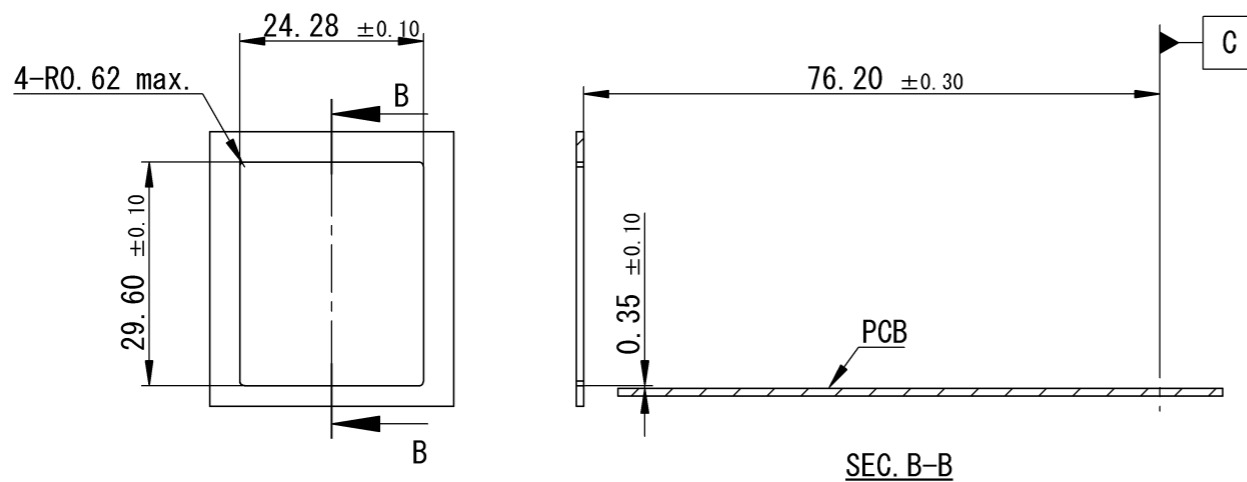

参考図

2021/12/14 山一電機株式会社 YAMAICHI ELECTRONICS Co.,Ltd.							
指定外公差 ±0.3 Tolerances ±0.3 unless otherwise specified. ()寸法は参考値 ()Reference value.							
尺度 SCALE	2 / 1	承認 APP.	承認 APP.	検図 CHK.	製図 DRW.	設計 DSNL	名称 (TITLE)
単位 DIMENSION	mm	20/12/24	20/12/24	20/12/23	20/12/17	20/12/17	OSFP STACK CAGE
三角図法 3RD. ANGLE PROJECTION	伊東	佐藤	高居	圓城寺	圓城寺		CN176D-1002-01
							図番 (DRW. NO.) A121968-001
							Sheet No. 2/
							REV. A