



DTR-2488-SM-LC/LS-W-G-CWDM

OC-48/STM-16 2x5 SFF Single Mode CWDM Transceivers



Features

- ☑ Eight (8) Wavelength CWDM Transceivers
- ☑ Compliant with SONET/SDH OC-48/STM-16 IR-2/S-16.2 & LR-2/L-16.2 Specifications
- ☑ Eye Safe (Class I Laser Safety)
- ☑ Multi-sourced 2x5 Package Style
- ☑ Duplex LC Optical Interface
- ☑ AC Coupling or DC Coupling Option to LV-PECL DATA Compatible Interface
- ☑ LV-TTL SIGNAL DETECT Output
- ☑ Metal Package for Excellent EMI Shielding
- ☑ Single +3.3V Power Supply

Description

The DTR-2488-SM-LC/LS-W-G-CWDM SFF series of fiber optic transceivers provide a quick and reliable interface for intermediate reach (IR-2) and long reach (LR-2) applications. Products under this series are compliant with SONET/SDH OC-48/STM-16 (2.488Gb/s) standards for IR-2/S-16.2 intermediate reach and LR-2/L-16.2 long reach applications, and are available in eight (8) wavelengths: 1470nm, 1490nm, 1510nm, 1530nm, 1550nm, 1570nm, 1590nm and 1610nm. Two performance options are available. In option L0, a guaranteed minimum optical power of -5dBm is offered with a PIN receiver that corresponds to a link distance of 15km (assuming fiber loss of 0.25dB/km). In option HP, a guaranteed minimum optical power of -2dBm is offered with an APD receiver that corresponds to a link distance of 80km (assuming fiber loss of 0.25dB/km). All modules satisfy Class I Laser Safety requirements in accordance with the U.S. FDA/CDRH and international IEC-60825 standards. The transmit and receive functions are contained in a narrow

width two-row, 10-pin (2x5) package with a duplex LC optical interface. The receptacle fits into an RJ-45 form factor outline. The 10-pin configuration is in conformance to the SFF MSA.

The transmitter design incorporates the necessary control and driver circuitry for converting differential data to light. The receiver uses an InGaAs/InP PIN photodiode for IR-2 applications and an APD photodiode for LR-2 applications to convert the light signal into an electrical current which is amplified and regenerated into differential data outputs. AC-coupled transmit and receive DATA interface is recommended for compatibility with LV-PECL signal levels. An option for DC-coupled interface is also available. LV-TTL SIGNAL DETECT function is provided to indicate optical input loss.

The transceivers operate from a single +3.3V power supply over an operating case temperature range of -5°C to +70°C. The housing is made of metal to enhance EMI immunity.

Absolute Maximum Ratings

Parameter	Symbol	Minimum	Maximum	Units
Storage Temperature	T_{st}	- 40	+ 85	°C
Operating Case Temperature	T_{op}	- 5	+ 70	°C
Maximum Input Optical Power (LR-2 only, 60 seconds max.)	$P_{in, max}$	-	+ 3.0	dBm
Supply Voltage	V_{CC}	0	+ 4.5	V
Input Voltage	V_{in}	0	V_{CC}	V
Output Current	I_O	-	50	mA
Lead Soldering Temperature & Time	-	-	260°C, 10 seconds	

DTR-2488-SM-LC/LS-W-G-CWDM

Transmitter Performance Characteristics (Over Operating Case Temperature Range, $V_{CC} = 3.13$ to $3.47V$)

All parameters guaranteed only at typical data rate

Parameter		Symbol	Minimum	Typical	Maximum	Units
Operating Data Rate ¹		B	-	2.488	-	Gb/s
Average Optical Output Power (coupled into single mode fiber) 50% duty cycle	L0	P_o	- 5.0	- 2.0	0	dBm
	HP		- 2.0	0	+ 3.0	
Extinction Ratio		P_{hi}/P_{lo}	8.2	-	-	dB
Center Wavelength	1470	λ_c	1464	1470	1477.5	nm
	1490		1484	1490	1497.5	
	1510		1504	1510	1517.5	
	1530		1524	1530	1537.5	
	1550		1544	1550	1557.5	
	1570		1564	1570	1577.5	
	1590		1584	1590	1597.5	
	1610		1604	1610	1617.5	
Spectral Width (-20dB)		$\Delta\lambda_{20}$	-	-	1.0	nm
Side Mode Suppression Ratio		$SMSR$	30	-	-	dB
Dispersion Penalty	IR-2	-	-	-	1.0	dB
	LR-2 ²		-	-	2.0	
Optical Output Eye		Compliant with Telcordia GR-253-CORE and ITU-T Recommendation G.957				
¹ Data rate ranges from 155Mb/s to 2.7Gb/s. However, some degradation may be incurred in overall performance.						
² Specified at 1600ps/nm dispersion, which corresponds to the approximate worst-case dispersion for 80km G.652/G.654 fiber over the wavelength range of 1464 - 1617.5nm.						

Receiver Performance Characteristics (Over Operating Case Temperature Range, $V_{CC} = 3.13$ to $3.47V$)

All parameters guaranteed only at typical data rate

Parameter		Symbol	Minimum	Typical	Maximum	Units	
Operating Data Rate ¹		B	-	2.488	-	Gb/s	
Receiver Sensitivity (10^{-10} BER) ²	IR-2	P_{min}	- 19.0	-	-	dBm	
	LR-2		- 29.0	- 31.0	-		
Maximum Input Optical Power (10^{-10} BER) ²	IR-2	P_{max}	0	+ 1.0	-	dBm	
	LR-2		- 8.0	-	-		
SIGNAL DETECT Thresholds	IR-2	Increasing Light input	P_{sd+}	-	-	- 19.0	dBm
		Decreasing Light Input	P_{sd-}	- 42.0	-	-	
	LR-2	Increasing Light input	P_{sd+}	-	-	- 29.0	
		Decreasing Light Input	P_{sd-}	- 42.0	-	-	
SIGNAL DETECT Timing		-	3.0	-	100	μ s	
SIGNAL DETECT Hysteresis		-	0.5	1.0	-	dB	
Wavelength of Operation		λ	1260	-	1620	nm	
¹ Data rate ranges from 155Mb/s to 2.7Gb/s. However, some degradation may be incurred in overall performance.							
² Specified in average optical input power and measured at 2.488Gb/s and 1550nm with 2 ²³ -1 PRBS.							

Laser Safety: All transmitters are Class I Laser products per FDA/CDRH and IEC-60825 standards. They must be operated under specified operating conditions.



Optical Communication Products, Inc.

DATE OF MANUFACTURE:

MANUFACTURED IN THE USA

This product complies with

21 CFR 1040.10 and 1040.11

Meets Class I Laser Safety Requirements

DTR-2488-SM-LC/LS-W-G-CWDM

Transmitter Electrical Interface (Over Operating Case Temperature Range, $V_{CC} = 3.13$ to $3.47V$)

Parameter	Symbol	Minimum	Typical	Maximum	Units
Input Voltage Swing between DATA+ & DATA-	V_{INDIF}	0.30	0.80	1.60	V_{P-P}
Input Impedance	Z_{IL}	-	50	-	Ω
Transmitter Disable Voltage	V_{DIS}	$V_{CC} - 1.3$	-	V_{CC}	V
Transmitter Enable Voltage	V_{EN}	0	-	0.8	V

Receiver Electrical Interface (Over Operating Case Temperature Range, $V_{CC} = 3.13$ to $3.47V$)

Parameter	Symbol	Minimum	Typical	Maximum	Units
Output HIGH Voltage (LV-PECL) ^{1,2}	V_{OH}	$V_{CC} - 1.10$	-	$V_{CC} - 0.90$	V
Output LOW Voltage (LV-PECL) ^{1,2}	V_{OL}	$V_{CC} - 1.84$	-	$V_{CC} - 1.60$	V
Output Current	I_O	-	-	25	mA
Output HIGH Voltage (LV-TTL)	V_{OH}	2.0	-	V_{CC}	V
Output LOW Voltage (LV-TTL)	V_{OL}	0	-	0.4	V

¹With 50Ω terminated to $V_{CC} - 2V$ (for DC-coupled modules).

²For AC-coupled modules, the output voltage swing into 50Ω load is 0.3V minimum and 0.8V maximum single-ended.

Electrical Power Supply Characteristics (Over Operating Case Temperature Range, $V_{CC} = 3.13$ to $3.47V$)

Parameter	Symbol	Minimum	Typical	Maximum	Units
Supply Voltage	V_{CC}	3.13	3.3	3.47	V
Supply Current ¹	AC-coupled modules	-	200	250	mA
	DC-coupled modules	-	180	230	

¹Supply current does not include termination resistor current.

Pin Assignment

PIN	FUNCTION	PIN	FUNCTION
1	RX GND	6	$V_{CC}TX$
2	$V_{CC}RX$	7	TX GND
3	SD (RX SIGNAL DETECT)	8	TX DISABLE
4	RD- (RX DATA OUT-)	9	TD+ (TX DATA IN+)
5	RD+ (RX DATA OUT+)	10	TD- (TX DATA IN-)

DTR-2488-SM-LC/LS-W-G-CWDM

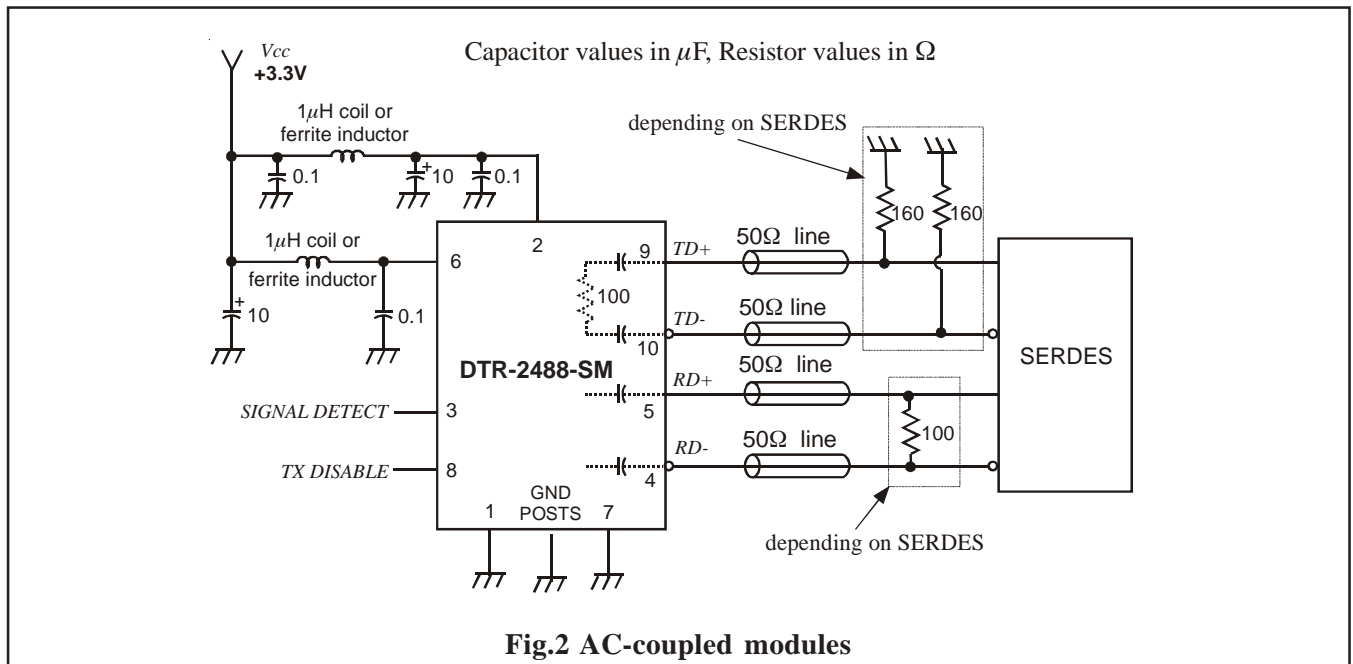
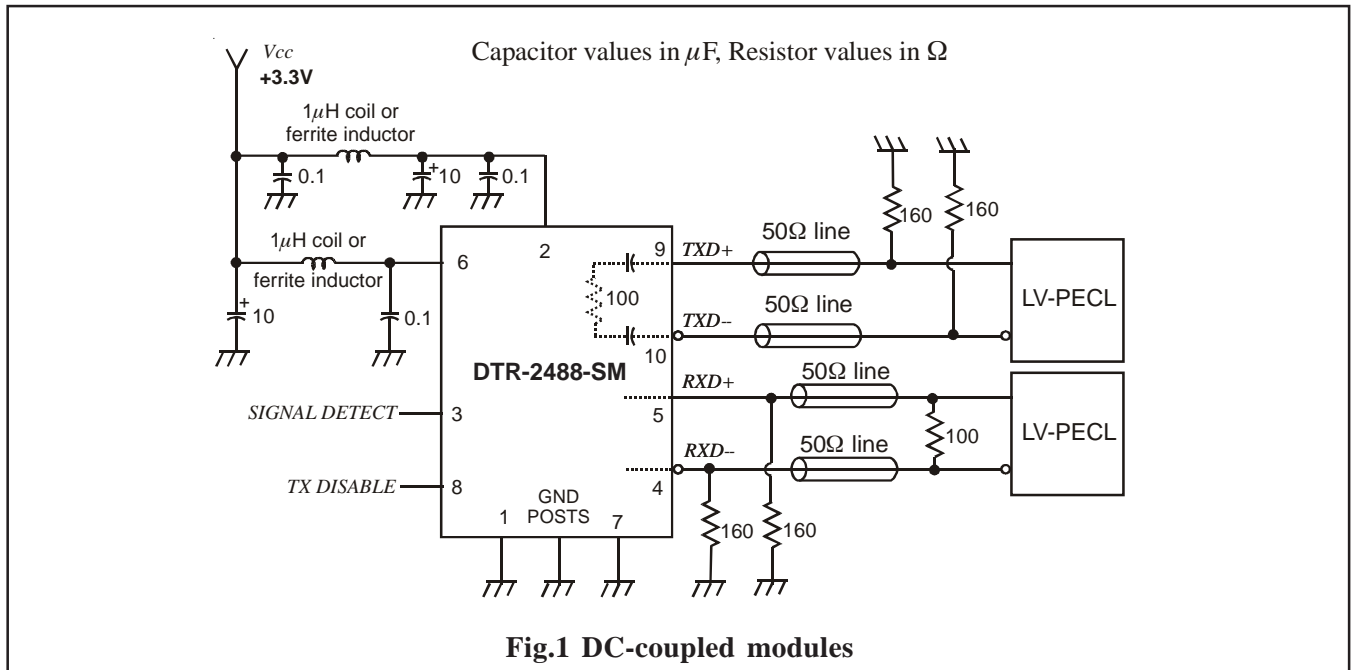

Application Notes

DATA interface (DC-coupled modules): The interface circuit for standard DC-coupled modules with direct-coupled LV-PECL interface is shown in Fig. 1. The transmitter input has internal 50Ω termination.

DATA interface (AC-coupled modules): For modules with AC coupling option, both transmitter and receiver interfaces have internal bias, 50Ω termination and AC coupling capacitors. The transmitter can be connected directly to the driving SERDES as shown in Fig. 2. The receiver can be connected directly to the external 50Ω loads (termination resistor of the SERDES). For best performance, both DATA+ & DATA- should be used.

SIGNAL DETECT: The SIGNAL DETECT circuit monitors the incoming optical signal level and generates a logic LOW signal when an insufficient photocurrent is produced. The output is LV-TTL with no termination required.

TX DISABLE: The transmitter is normally enabled (i.e. when the TX DISABLE control input is not connected). When the TX DISABLE control input voltage is higher than $V_{CC} - 1.3\text{V}$, the laser is turned off independent of the input data.

Power supply and grounding: The power supply line should be well-filtered. All $0.1\mu\text{F}$ power supply bypass capacitors should be as close to the DTR transceiver module as possible. The module case ground is internally AC-coupled to the circuit ground.

DTR-2488-SM-LC/LS-W-G-CWDM

Package without EMI Shield (LC)

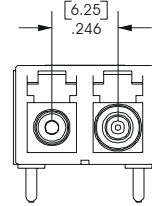
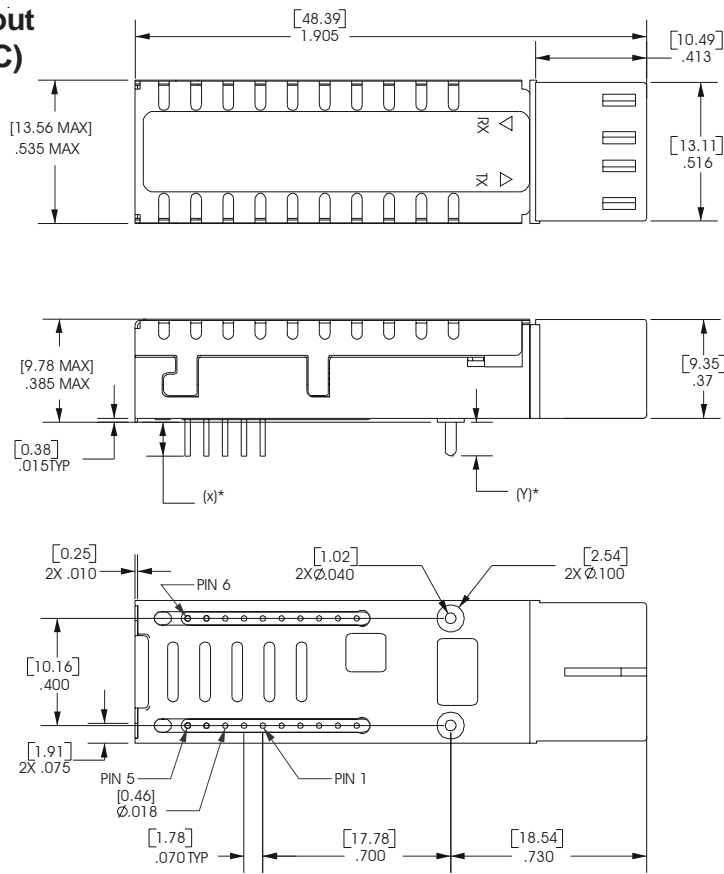

*(x) & (y): See Pin Length Option Table in Ordering Information

Dimensions in inches [mm]
 Default tolerances:
 .xxx ± .005", .xx ± .01"

Package with EMI Shield (LS)

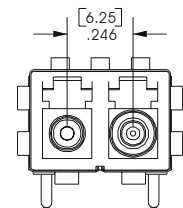
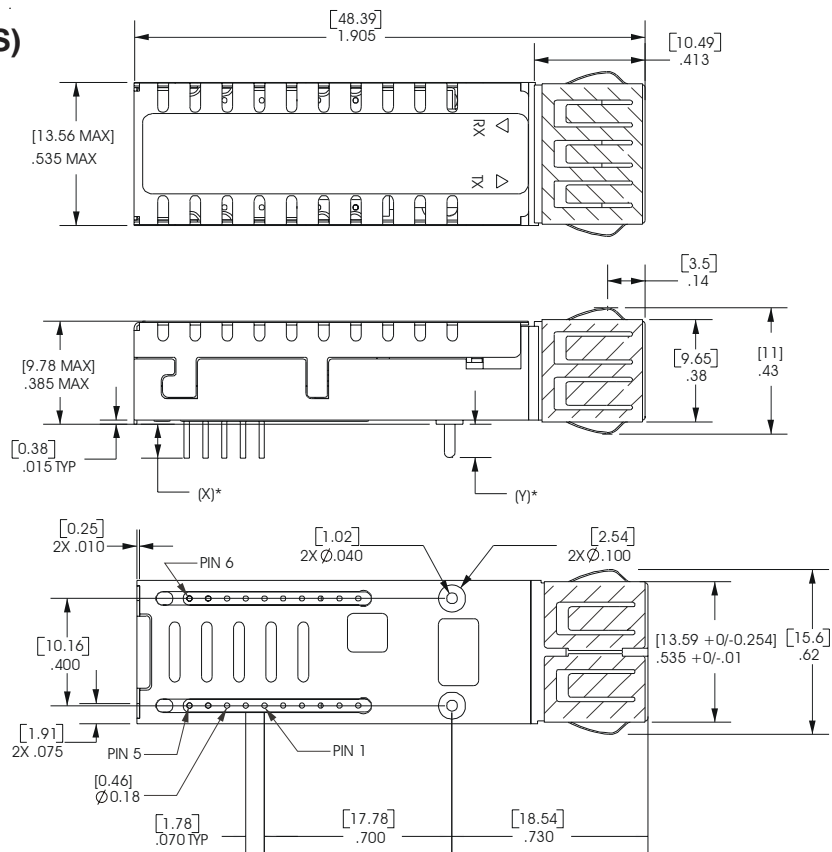

*(x) & (y): See Pin Length Option Table in Ordering Information

Dimensions in inches [mm]
 Default tolerances:
 .xxx ± .005", .xx ± .01"

DTR-2488-SM-LC/LS-W-G-CWDM

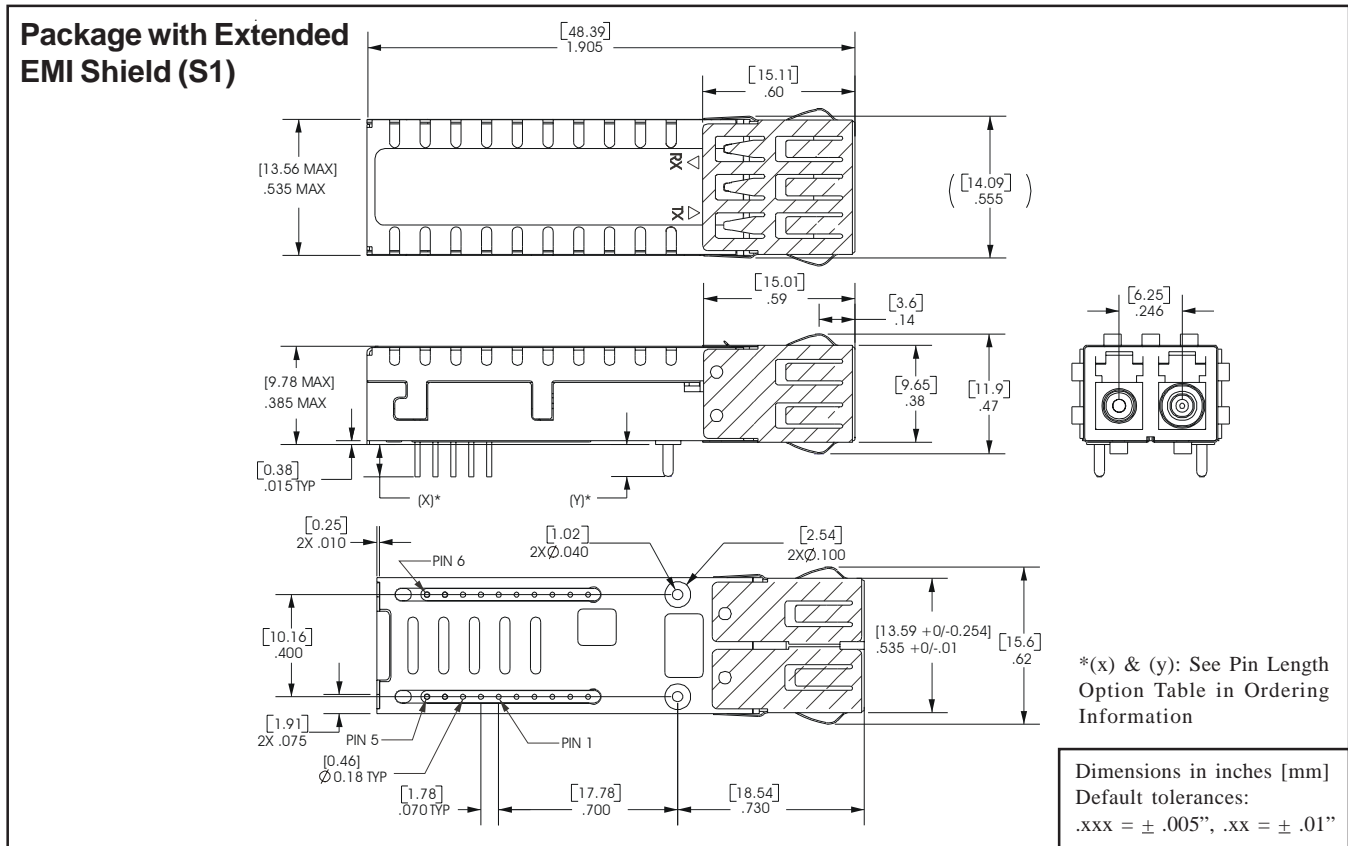

Ordering Information

DTR - 2488 - SM - *Lx* - *Ln* - DR - *XX* - *Wp* - G - *Cxxx* - *S1*

Connector
 LC : w/o EMI Shield
 LS : w/ EMI Shield
 or w/ Extended S1 Shield

Light Output Option
 L0 : -5 to 0dBm (IR-2)
 HP : -2 to +3dBm (LR-2)

Distance Option (see Note)
 IR2 : IR-2/S-16.2 (42/15km)
 LR2 : LR-2/L-16.2 (80km)

Extended Shield
 "Blank" : None
 "S1" : Extended EMI Shield

Center Wavelength
 C470: 1470nm
 C490: 1490nm
 C510: 1510nm
 C530: 1530nm
 C550: 1550nm
 C570: 1570nm
 C590: 1590nm
 C610: 1610nm

see Pin Length Option Table

Receiver Coupling Option
 "Blank" : DC Coupling
 "AC" : AC Coupling

Pin Length Option Table

Options (p)	Pin Length (x)		Post Length (y)	
	Inches	Millimeters	Inches	Millimeters
"blank"	0.140 ± 0.010	3.56 ± 0.250	0.125 + 0.010 - 0.005	3.17 + 0.250 - 0.125
5	0.155 ± 0.010	3.94 ± 0.250	0.155 + 0.010 - 0.005	3.94 + 0.250 - 0.125
8	0.180 ± 0.010	4.57 ± 0.250	0.180 + 0.010 - 0.005	4.57 + 0.250 - 0.125

Note:
 These are target distances to be used for classification and not for specification, per Telcordia GR-253-CORE/ITU-T Recommendation G.957.

Optical Communication Products, Inc.

6101 Variel Avenue, Woodland Hills, CA 91367, Tel.: 818-251-7100, FAX: 818-251-7111, www.ocp-inc.com

Optical Communication Products, Inc. reserves the right to make changes in equipment design or specifications without notice. Information supplied by Optical Communication Products, Inc. is believed to be accurate and reliable. However, no responsibility is assumed by Optical Communication Products, Inc. for its use nor for any infringements of third parties, which may result from its use. No license is granted by implication or otherwise under any patent right of Optical Communication Products, Inc.

© 2005, Optical Communication Products, Inc.