



HI1206T161R-10

UNCONTROLLED DOCUMENT

PHYSICAL DIMENSIONS:

A	3.20 [.126]	+ 0.20 [.008]
B	1.60 [.063]	+ 0.20 [.008]
C	1.60 [.063]	+ 0.20 [.008]
D	0.51 [.020]	+ 0.25 [.010]

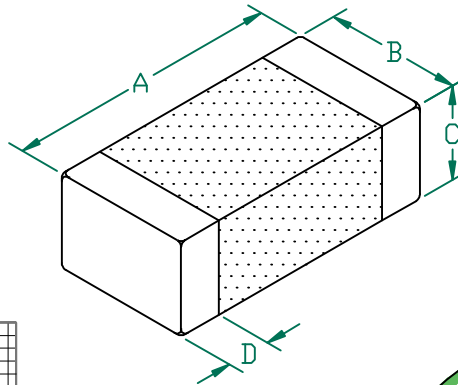

ELECTRICAL CHARACTERISTICS:		
Z @ 100MHz (Ω)	DCR (Ω)	Rated Current
Nominal	160	
Minimum	120	
Maximum	208	6000 mA

Z vs FREQUENCY
IMPEDANCE UNDER DC BIAS

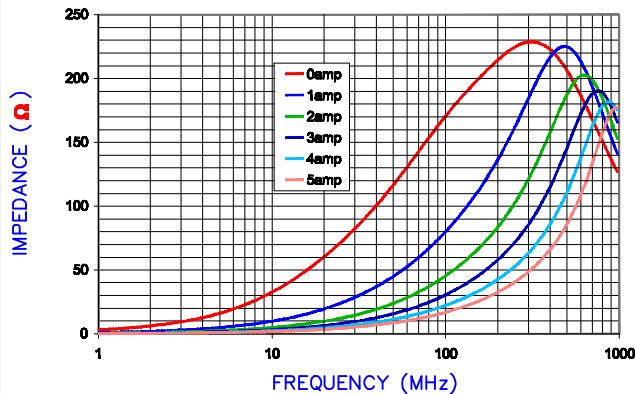

|Z|, R, AND X vs. FREQUENCY

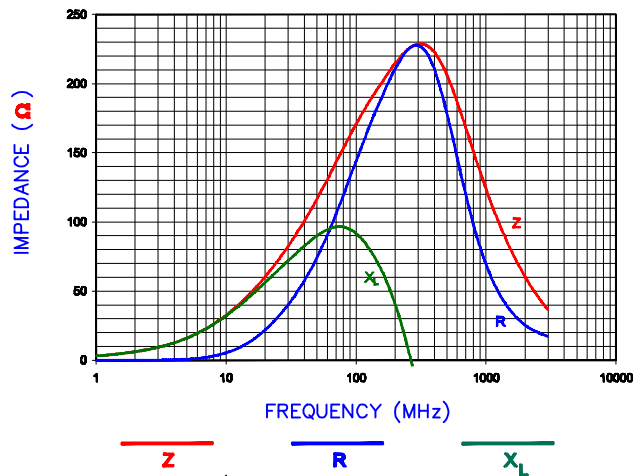

- NOTES: UNLESS OTHERWISE SPECIFIED
1. TAPED AND REELED per CURRENT EIA SPECIFICATIONS 7" REELS, 2000 PCS/REEL, EMBOSSED PLASTIC TAPE.
 2. COMPONENTS SHOULD BE ADEQUATELY PREHEATED BEFORE SOLDERING.
 3. TERMINATION FINISH IS 100% TIN.

LAND PATTERNS FOR REFLOW SOLDERING

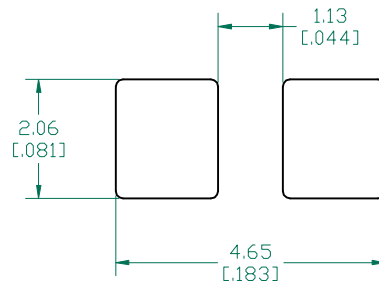

(For wave soldering, add 0.762 [0.030] to this dimension)

RECOMMENDED SOLDERING CONDITIONS

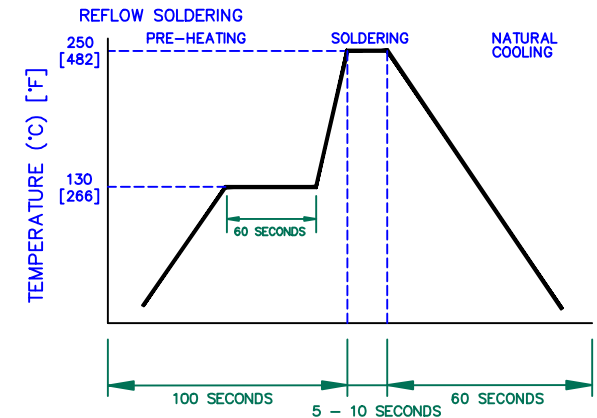

DIMENSIONS ARE IN mm [INCHES].				This print is the property of Laird Tech. and is loaned in confidence subject to return upon request and with the understanding that no copies shall be made without the written consent of Laird Tech. All rights to design or invention are reserved.	
F	UPDATE COMPANY LOGO	10/09/08	TMB		
E	ADD EMBOSSED PLASTIC TAPE TO NOTE 1	01/19/07	JRK		
D	CHANGE C DIMENSION	01/15/07	JRK		
C	CHG REEL QTY ADD ROHS SYMBOL	08/28/06	JRK		
B	CHANGE MAXIMUM IMPEDANCE FROM 200	01/11/05	JRK		
A	ORIGINAL DRAFT	01/13/04	JRK	DATE: 01/13/04	SCALE: NTS
REV	DESCRIPTION	DATE	INT	GAD # HI1206T161R-10-F	TOOL # -