



American Opto Plus LED L150GC-TR

3.2 x 1.6 x 1.1mm SMD LED, Tape & Reel

- ❖ 3.2 x 1.6 x 1.1mm SMD LED
- ❖ 120° VIEWING ANGLE
- ❖ LOW POWER CONSUMPTION
- ❖ LOW CURRENT REQUIREMENT

Package Dimension

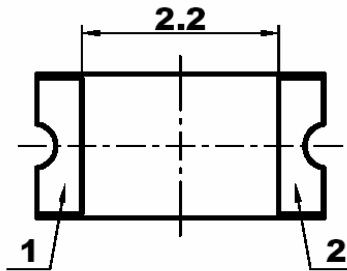
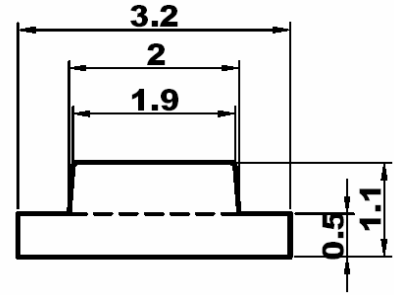
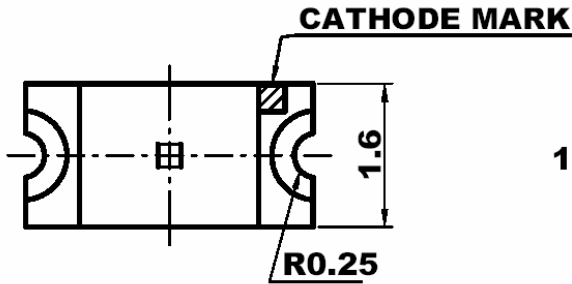

Notes: Unit = mm, Tolerance = ± 0.25 mm

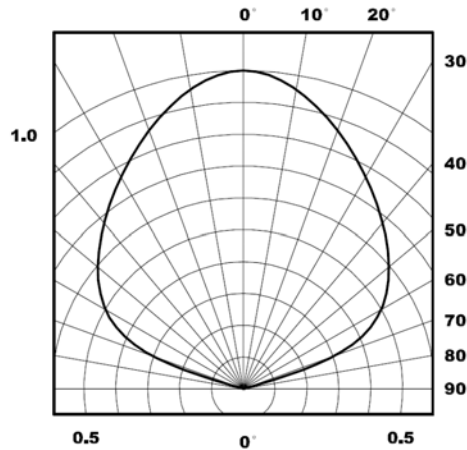

Viewing Angle $2\theta_{1/2} = 120^\circ$

Part Number	Chip		Lens Type	Iv (I _F = 20mA)	
	Material	Emitted Color		Min (mcd)	Typ (mcd)
L150GC-TR	GaP	Green	Water Clear	5	18



American Opto Plus LED

L150GC-TR

3.2 x 1.6 x 1.1mm SMD LED, Tape & Reel

- ❖ 3.2 x 1.6 x 1.1mm SMD LED
- ❖ 120° VIEWING ANGLE
- ❖ LOW POWER CONSUMPTION
- ❖ LOW CURRENT REQUIREMENT

Absolute maximum ratings (TA=25°C)		(GaP)	Unit
Reverse voltage	V_R	5	V
Forward current (max.)	I_F	25	mA
Forward current(Peak)	I_{FP}	100	mA
1/10 Duty Cycle,0.1ms Pulse Width			
Power dissipation (avg.)	P_d	40	mW
LED LAMPS:			
Operating temperature	T_{OP}	-40~+85	°C
Storage temperature	T_{ST}	-40~+85	°C
LED DISPLAYS:			
Operating temperature	T_A	-40~+85	°C
Storage temperature	T_{STG}	-40~+85	°C

Operating characteristics (TA=25°C)		(GaP)	Unit
Forward voltage(typ.)	V_F	2.2	V
$I_F = 20\text{mA}$			
Forward voltage(max.)	V_F	2.6	V
$I_F = 20\text{mA}$			
Reverse current(max.)	I_R	10	uA
$V_R = 5\text{V}$			
Wavelength at dominant emission(typ.)	λ_D	570	nm
$I_F = 20\text{mA}$			
Wavelength at peak emission(typ.)	λ_P	568	nm
$I_F = 20\text{mA}$			
Spectral line half-width	$\Delta \lambda$	30	nm
$I_F = 20\text{mA}$			
Capacitance	C	45	pF
$V_F = 0\text{V}, f = 1\text{MHz}$			



American Opto Plus LED L150GC-TR

3.2 x 1.6 x 1.1mm SMD LED, Tape & Reel

- ❖ 3.2 x 1.6 x 1.1mm SMD LED
- ❖ 120° VIEWING ANGLE
- ❖ LOW POWER CONSUMPTION
- ❖ LOW CURRENT REQUIREMENT

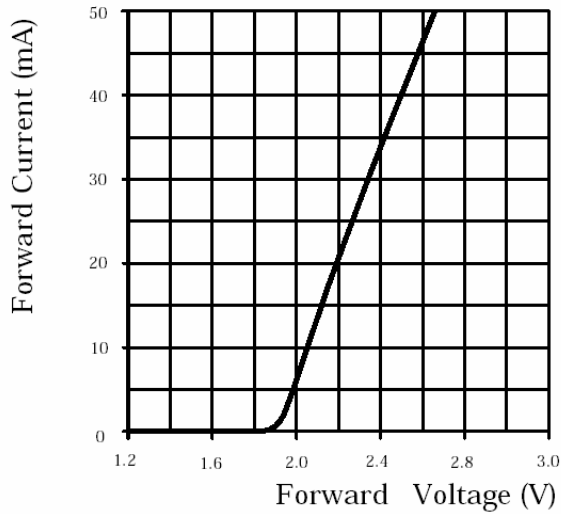

Forward Current Vs.
Forward Voltage

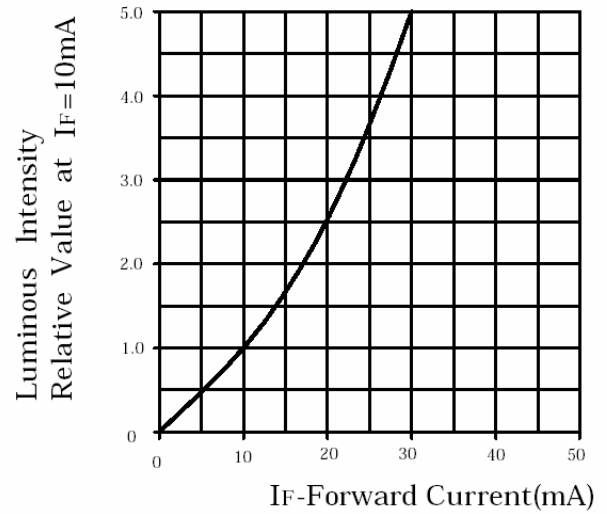

Luminous Intensity Vs.
Forward Current

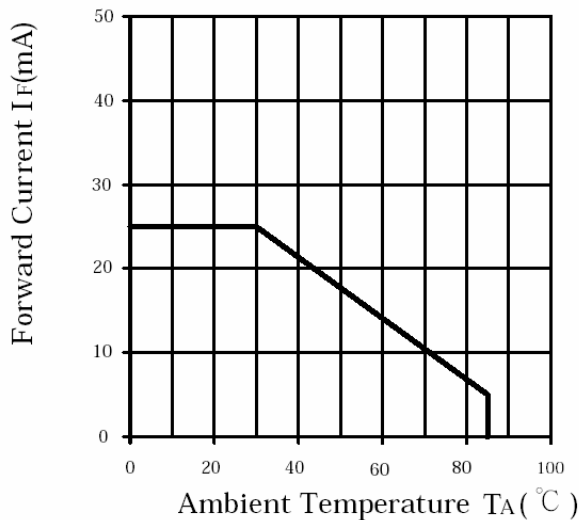

Forward Current
Derating Curve

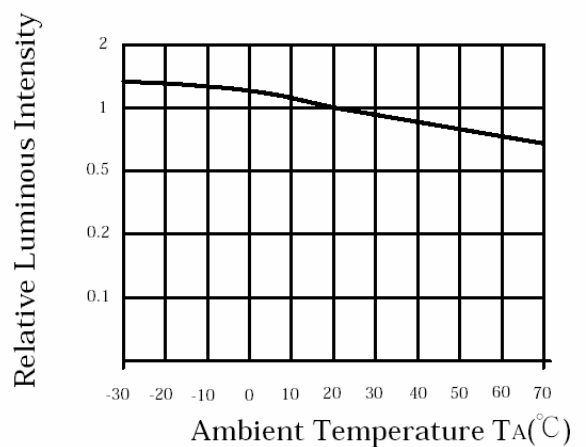

Luminous Intensity Vs.
Ambient Temperature



American Opto Plus LED L150GC-TR

3.2 x 1.6 x 1.1mm SMD LED, Tape & Reel

- ❖ 3.2 x 1.6 x 1.1mm SMD LED
- ❖ 120° VIEWING ANGLE
- ❖ LOW POWER CONSUMPTION
- ❖ LOW CURRENT REQUIREMENT

Tape Dimension

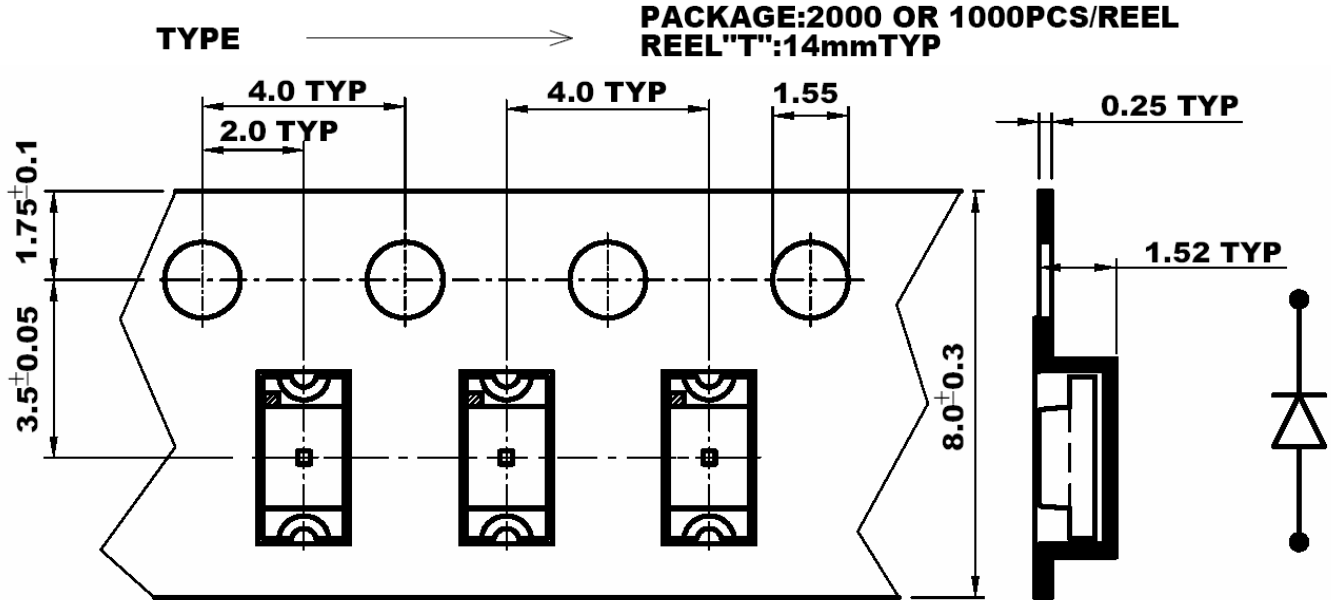

Reel Dimension

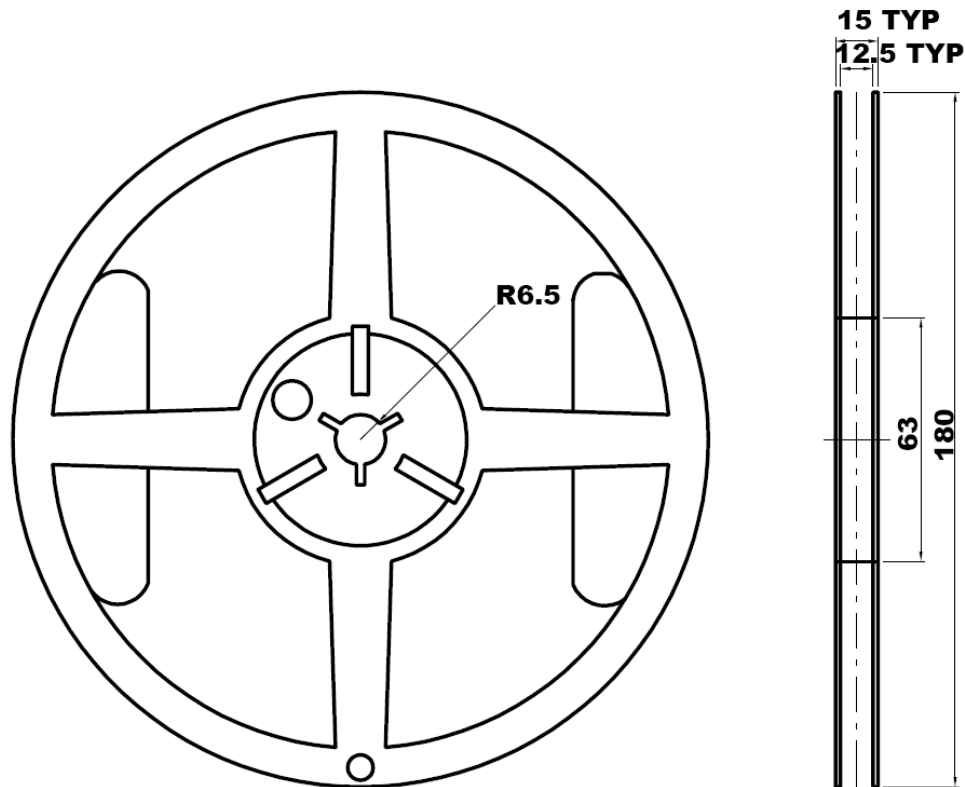

Notes: Unit = mm, Tolerance = ± 0.25 mm



American Opto Plus LED L150GC-TR

3.2 x 1.6 x 1.1mm SMD LED, Tape & Reel

- ❖ 3.2 x 1.6 x 1.1mm SMD LED
- ❖ 120° VIEWING ANGLE
- ❖ LOW POWER CONSUMPTION
- ❖ LOW CURRENT REQUIREMENT

Reflow Soldering Pattern (Unit = mm)

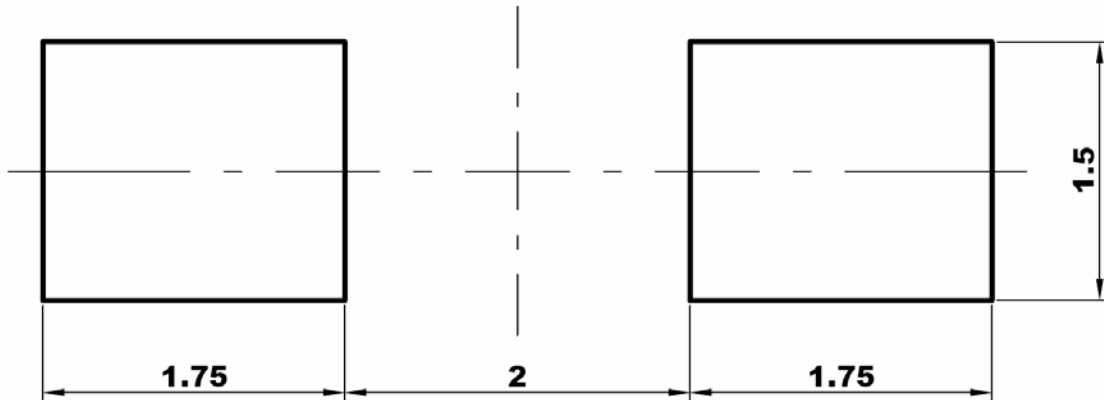

SMD Reflow Soldering Instructions

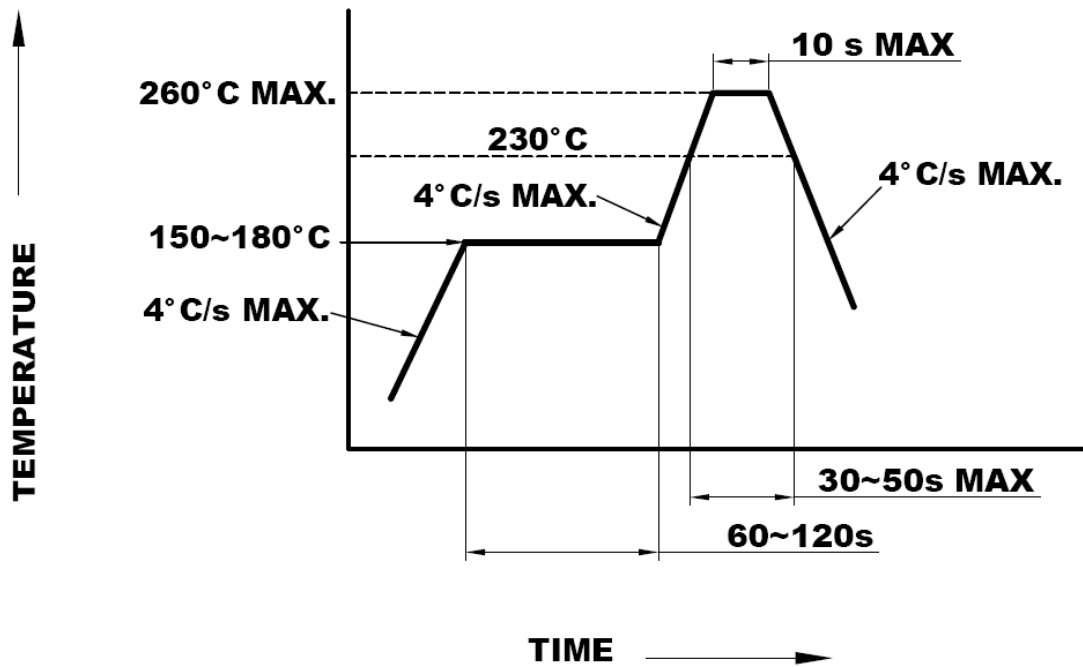

SMT Reflow soldering 260°C one cycle



American Opto Plus LED L150GC-TR

3.2 x 1.6 x 1.1mm SMD LED, Tape & Reel

- ❖ 3.2 x 1.6 x 1.1mm SMD LED
- ❖ 120° VIEWING ANGLE
- ❖ LOW POWER CONSUMPTION
- ❖ LOW CURRENT REQUIREMENT

SMD Handling and Application Precautions

STORAGE

1. It is recommended to store the devices in accordance with the following conditions:
 - a. Humidity: 60% RH Max
 - b. Temperature: 5°C ~ 30°C (41°F ~ 86°F)
2. Shelf life in sealed bag: 12 months at < 5°C ~ 30°C and < 60% RH. After the package is opened, products should be used within 72 hours, or they should be kept at ≤ 30% RH in zip-locked sealed bags.

DRY PACK AND BAKING

SMD LEDs are MOISTURE SENSITIVE devices. Avoid absorbing moisture at any time during transportation and/or storage. It is recommended to bake before soldering when the pack is unsealed after 72 hours, or any suspicious moisture being found. Bake devices in accordance with the following conditions:

- 50 ± 3°C x (12 ~ 24 hours) and < 5% RH, tape and reel type
- 100 ± 3°C x (45 min ~ 1 hour), loose packing type, OR
- 130 ± 3°C x (15 min ~ 30 min), loose packing type

ELECTROSTATIC DISCHARGE (ESD) PROTECTION

Materials with GaN, InGaN, AlInGaP are STATIC SENSITIVE devices. They will be packed in anti-static bags. ESD protection must be deliberately observed from the initial design stage. Electrostatic discharge may result in severe malfunction of devices. In the event of manual working in process, make sure the devices are well-protected from ESD at any time. Surge before and during handling of products.